

SE 110.48

Bending test, plastic deformation



The illustration shows SE 110.48 in a frame similar to SE 112.

Description

- **observe and determine the transition from elastic to plastic deformation**
- **plot load–extension diagrams**

Mechanical stress, to which design elements are generally exposed, generates stresses in the affected component or the material. If these stresses are too large, there is plastic deformation of the material in addition to the elastic, reversible deformation. The component does not return fully to its original form after the deformation, resulting in a change of shape.

The beam studied in SE 110.48 is mounted on both sides. A movable and a fixed support are included in the scope of delivery to secure the beam. The beam is loaded with a point load. The load application device can be positioned anywhere on the frame. A dial gauge records the deformation. Beams of different materials and profiles are included in the scope of delivery.

The transition from elastic to plastic deformation is observed and determined in the experiment. The values obtained are used to create a load–extension diagram, in which the nonlinear behaviour of the deformation is demonstrated.

The parts of the experiment are laid out clearly and housed securely in a storage system. The entire experimental setup is constructed in the SE 112 mounting frame.

Learning objectives/experiments

- load on a beam with a point load
- plot a load–extension diagram and determine the nonlinear behaviour
- compare the load and relief curves
- demonstrate the invalidity of the superposition principle in the plastic region

SE 110.48

Bending test, plastic deformation

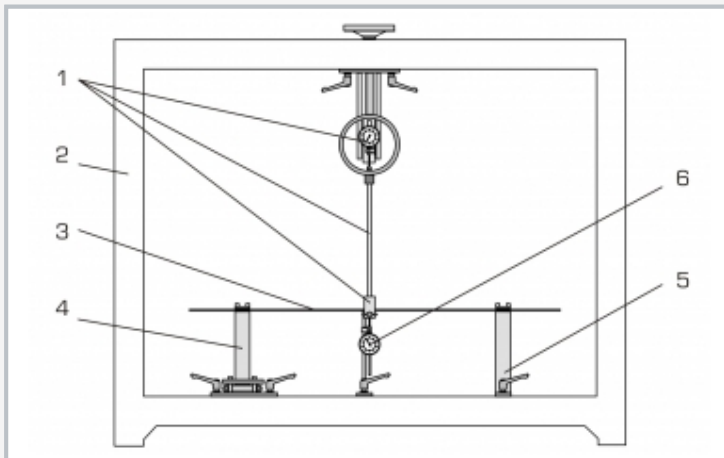

1 load application device, 2 SE 112 frame, 3 beam, 4 movable support, 5 fixed support, 6 dial gauge

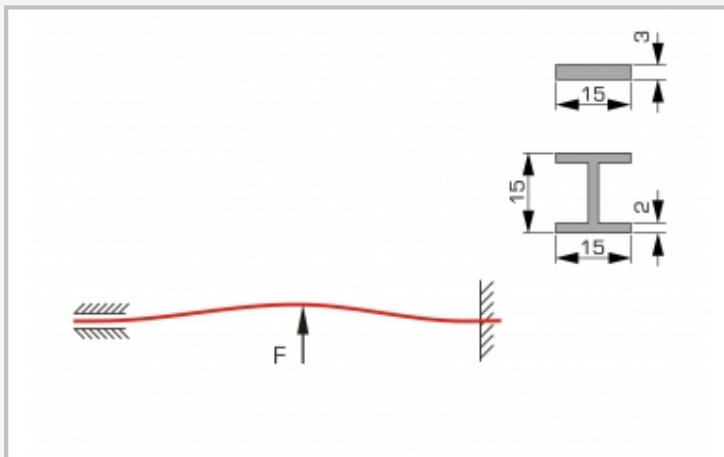

Plastic deformation of a beam, both beam profiles included in the scope of delivery

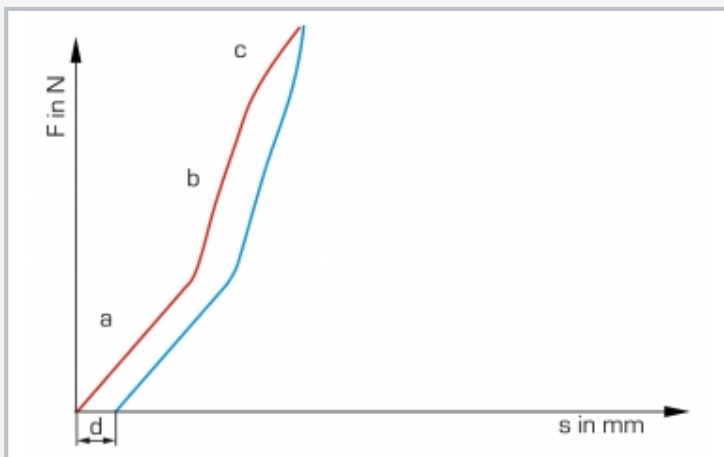

Load-extension diagram for red: load curve and blue: relief curve; a elastic region, b region of non-linear deformation, c plastic range, d permanent deformation; F force, s elongation

Specification

- [1] study a beam until plastic deformation
- [2] load on the beam from point load
- [3] fixed and movable support for supporting the beam
- [4] beams of different materials and profiles
- [5] dial gauge for recording the deformation
- [6] storage system for parts
- [7] experimental setup in the SE 112 mounting frame

Technical data

Beams

- 1x 1000x15x3mm, steel
- 1x 1000x15x3mm, aluminium
- 1x H-profile, 1000x15x15x2mm, aluminium

Load application device

- max. load: $\pm 5000\text{N}$
- max. travel: 100mm

Measuring ranges

- travel: 0...50mm

LxWxH: 1170x480x178mm

Weight: approx. 30kg

Scope of delivery

- 1 set of beams (3 pieces)
- 1 load application device
- 2 supports
- 1 dial gauge
- 1 tension device
- 1 storage system with foam inlay
- 1 set of instructional material

SE 110.48

Bending test, plastic deformation

Required accessories

022.11200

SE 112

Mounting frame