

# Stefan-Boltzmann's law of radiation (Item No.: P2350101)

## Curricular Relevance

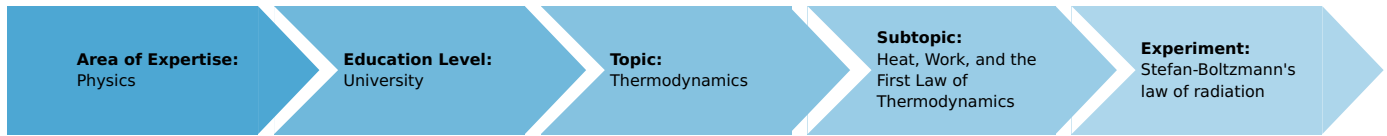

**Difficulty**



Difficult

**Preparation Time**



1 Hour

**Execution Time**



3 Hours

**Recommended Group Size**



2 Students

**Additional Requirements:**

**Experiment Variations:**

**Keywords:**

black body radiation, thermoelectric e.m.f., temperature dependence of resistances

## Overview

### Short description

**Principle**

According to Stefan-Boltzmann's law, the energy emitted by a black body per unit area and unit time is proportional to the power "four" of the absolute temperature of the body. Stefan-Boltzmann's law is also valid for a so-called "grey" body whose surface shows a wavelength-independent absorption-coefficient of less than one. In the experiment, the "grey" body is represented by the filament of an incandescent lamp whose energy emission is investigated as a function of the temperature.

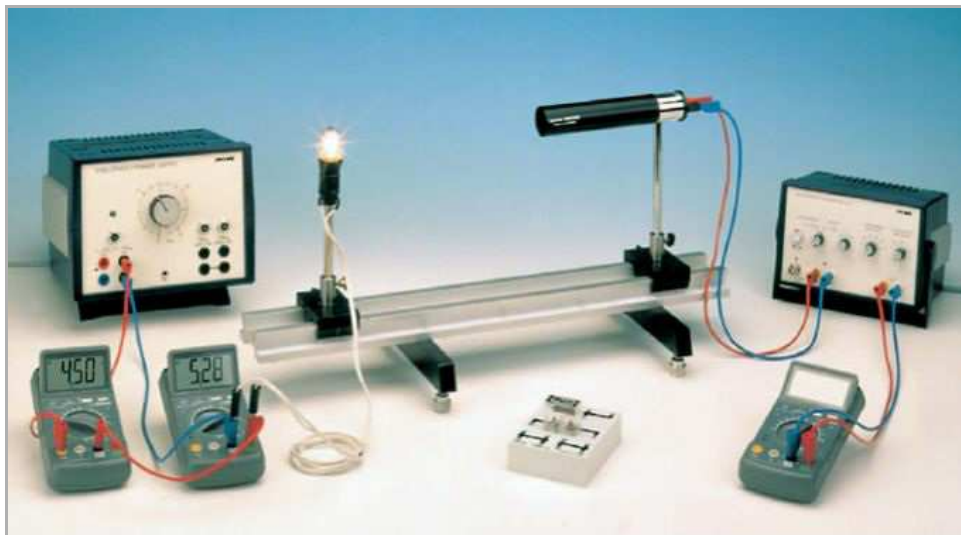

Figure 1: Set-up for experimental verification of Stefan-Boltzmann's law of radiation.

## Safety instructions



## Equipment

Position No.	Material	Order No.	Quantity
1	Optical bench expert I = 600 mm	08283-00	1
2	Base for optical bench expert, adjustable	08284-00	2
3	Slide mount for optical bench expert, h = 30 mm	08286-01	2
4	PHYWE Universal measuring amplifier	13626-93	1
5	Thermopile, Moll type	08479-00	1
6	Shielding tube, for 08479-00	08479-01	1
7	PHYWE power supply, variable DC: 12 V, 5 A / AC: 15 V, 5 A	13540-93	1
8	Lamp holder E 14, on stem	06175-00	1
9	Filament lamp 6V/5A, E14	06158-00	3
10	Connection box	06030-23	1
11	Resistor 100 Ohm 2%, 1W, G1	06057-10	1
12	Digital multimeter 2005	07129-00	3
13	Connecting cord, 32 A, 500 mm, blue	07361-04	4
14	Connecting cord, 32 A, 500 mm, red	07361-01	4

## Tasks

1. To measure the resistance of the filament of the incandescent lamp at room temperature and to ascertain the filament's resistance  $R_0$  at zero degrees centigrade.
2. To measure the energy flux density of the lamp at different heating voltages. The corresponding heating currents read off for each heating voltage and the corresponding filament resistance calculated. Anticipating a temperature-dependency of the second order of the filament-resistance, the temperature can be calculated from the measured resistances.

## Set-up and procedure



The experiment is started by setting up the circuit of Fig. 2 to measure the filament's resistance at room temperature. A resistor of 100 Ω is connected in series with the lamp to allow a fine adjustment of the current. For 100 mADC and 200 mADC the voltage drops across the filament are read and the resistance at room temperature is calculated. The current intensities are sufficiently small to neglect heating effects.

The experiment set-up of Fig. 1 is then built up. The 100 Ω resistor is no longer part of the circuit. The filament is now supplied by a variable AC-voltage source via an ammeter allowing measurement of alternating currents of up to 6 amperes. The voltmeter is branched across the filament and the alternating voltage is increased in steps of 1 volt up to a maximum of 8 V AC.

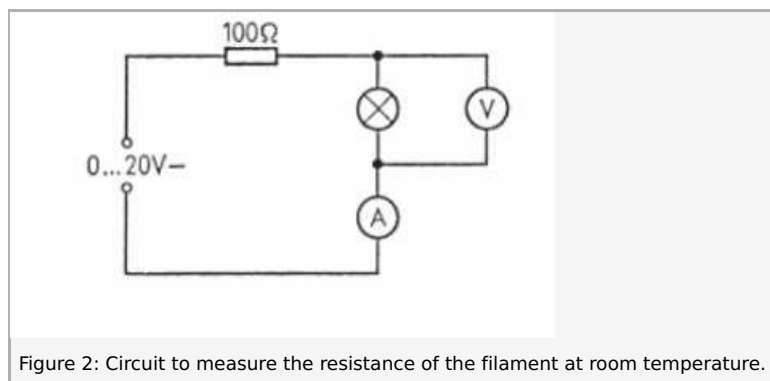

**Remark:** the supply voltage of the incandescent lamp is 6 V AC. A voltage of up to 8 V AC can be applied if the period of supply is limited to a few minutes.

Initially, a voltage of 1 V AC is applied to the lamp and the Moll-thermopile, which is at a distance of 30 cm from the filament, is turned (slide-mount fixed) to the right and to the left until the thermoelectric e.m.f. shows a maximum. The axis of the cylindrical filament should be perpendicular to the optical bench axis. Since the thermoelectric e.m.f. is in the order of magnitude of a few millivolts, an amplifier has to be used for accurate readings. The factor of amplification will be  $10^2$  or  $10^3$  when using the voltmeter connected to the amplifier in the 10 V range. Before a reading of the thermoelectric e.m.f. is taken, a proper "zero"-adjustment has to be assured. This is done by taking the lamp together with its slide-mount away from the bench for a few minutes. The amplifier is used in the LOW DRIFT-mode ( $10^4 \Omega$ ) with a time constant of 1 s.

After the lamp has been put back onto the bench, the reading can be taken if the Moll-thermopile has reached its equilibrium. This takes about one minute. Care must be taken that no background radiation disturbs the measurement.

## Theory and evaluation

If the energy flux density  $L$  of a black body, e.g. energy emitted per unit area and unit time at temperature  $T$  and wavelength  $\lambda$  within the interval  $d\lambda$ , is designated by  $dL(T, \lambda)/d\lambda$ ,

Planck's formula states:

$$\frac{dL(\lambda, T)}{d\lambda} = \frac{2c^2 h \lambda^{-5}}{e^{\frac{hc}{\lambda kT}}} \quad (1)$$

with

$c$	=velocity of light	$(3.00 \cdot 10^8 \text{ [m/s]})$
$h$	=Planck's constant	$(6.62 \cdot 10^{-34} \text{ [J} \cdot \text{s]})$
$k$	=Boltzmann's constant	$(1.381 \cdot 10^{-23} \text{ [J} \cdot \text{K}^{-1}])$

Integration of equation (1) over the total wavelength-range from  $\lambda = 0$  to  $\lambda = \infty$  gives the flux density  $L(T)$  (Stefan- Boltzmann's

law).

$$L(T) = \frac{2\pi^5}{15} \cdot \frac{k^4}{c^2 h^3} \cdot T^4 \quad (2)$$

Respectively  $L(T) = \sigma \cdot T^4$

with  $\sigma = 5.67 \cdot 10^{-8} [\text{W} \cdot \text{m}^2 \cdot \text{K}^{-4}]$

The proportionality  $L \sim T^4$  is also valid for a so-called "grey" body whose surface shows a wavelength-independent absorption-coefficient of less than one.

To prove the validity of Stefan-Boltzmann's law, we measure the radiation emitted by the filament of an incandescent lamp which represents a "grey" body fairly well. For a fixed distance between filament and thermopile, the energy flux  $\phi$  which hits the thermopile is proportional to  $L(T)$ .

$$\phi \sim L(T)$$

Because of the proportionality between  $\phi$  and the thermoelectric e.m.f.,  $U_{\text{therm}}$  of the thermopile, we can also write:

$$U_{\text{therm}} \sim T^4$$

if the thermopile is at a temperature of zero degrees Kelvin. Since the thermopile is at room temperature  $T_R$  it also radiates due to the  $T^4$  law so that we have to write:

$$U_{\text{therm}} \sim (T^4 - T_R^4)$$

Under the present circumstances, we can neglect  $T_R^4$  against  $T^4$  so that we should get a straight line with slope "4" when representing the function  $U_{\text{therm}} = f(T)$  double logarithmically.

$$\lg U_{\text{therm}} = 4 \lg T + \text{const.} \quad (3)$$

The absolute temperature  $T = t + 273$  of the filament is calculated from the measured resistances  $R(t)$  of the tungsten filament ( $t =$  temperature in centigrade). For the tungsten filament resistance, we have the following temperature dependence:

$$R(t) = R_0(1 + \alpha t + \beta t^2) \quad (4)$$

With  $R_0 =$  resistance at 0 °C

$$\alpha = 4.82 \cdot 10^{-3} \cdot K^{-1}$$

$$\beta = 6.76 \cdot 10^{-7} \cdot K^{-2}$$

The resistance  $R_0$  at 0 °C can be found by using the relation:

$$R_0 = \frac{R(t_R)}{1 + \alpha t_R + \beta t_R^2} \tag{5}$$

Solving  $R(t)$  with respect to  $t$  and using the relation  $T = t + 273$  gives:

$$T = 273 + \frac{1}{2\beta} \left( \sqrt{a^2 + 4\beta \left( \frac{R(t)}{R_0} - 1 \right)} - a \right) \tag{6}$$

$R(t_R)$  and  $R(t)$  are found by applying Ohm's law, e. g. by voltage and current measurements across the filament.

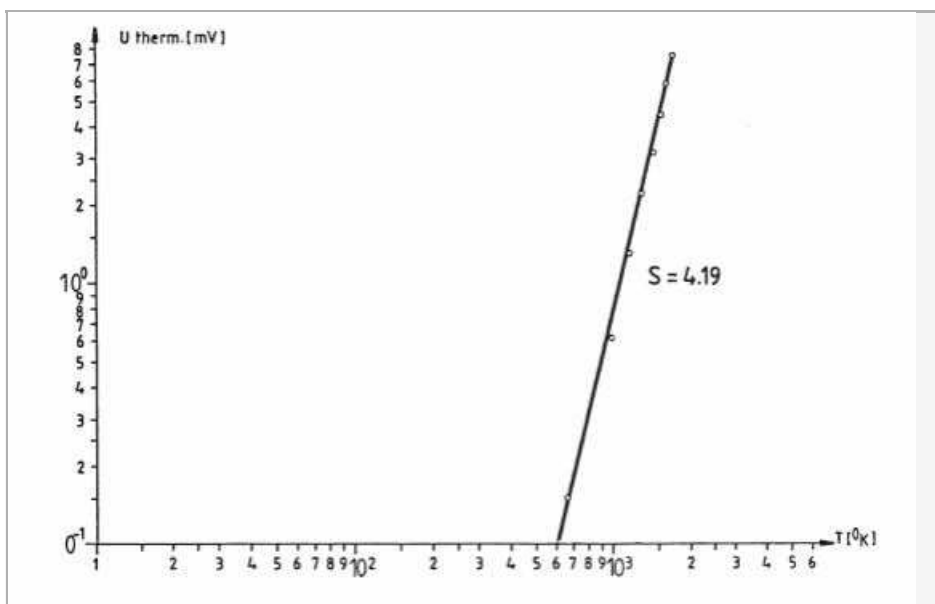

Figure 3: Thermoelectric e.m.f. of thermopile as a function of the filament's absolute temperature.

1. Using the DC voltage output of the power supply unit, a direct current of 100 mA, respectively 200 mA, was supplied to the filament via a 100 Ω resistor. The corresponding voltage drops were found to be 16.5 mV and 33.0 mV. Doubling the current doubles the voltage drop. This shows that the temperature influence on the resistance is still negligibly small for the DC values chosen. We find in this case

$$R(t_R) = 0.165 \Omega \tag{7}$$

and hence

$$R_0 = 0.15 \, \Omega \tag{8}$$

Small variations in  $R_0$  only influence the slope  $S$ , which is to be found, in a negligible way.

2. Increasing the AC heating voltage in steps of 1 V AC from 0 to 8 volts gave the following results:

$U$ [V]	$I$ [A]	$U_{\text{therm}}$ [mV]	$T$ [K]
1	2.20	0.15	672
2	2.80	0.62	983
3	3.45	1.30	1160
4	4.00	2.20	1300
5	4.45	3.20	1430
6	4.90	4.45	1540
7	5.30	5.90	1630
8	5.70	7.50	1720

The double logarithmic, graphical representation of the energy flux versus absolute temperature is shown in Fig. 3. The slope  $S$  of the straight line is calculated, by regression, to be:

$$S = 4.19 \pm 0.265 \tag{9}$$

The true value of  $S$ , which is 4, is found to be within the limits or error.