

TM 150

Vibration trainer



Learning objectives/experiments

- experiments with pendulums
 - ▶ Kater's pendulum
 - ▶ reduced pendulum length
 - ▶ spring-mass system
- bar-type oscillator
 - ▶ undamped oscillation
 - ▶ damped oscillation
 - ▶ forced vibration
- damped and undamped resonance
- absorber effect in multi-mass oscillators

Description

- detailed, wide-ranging series of experiments on the mechanical vibration theory
- experiments on various pendulums, bar-type oscillators and spring-mass systems
- damping, resonance and absorber effects in forced vibrations

Mechanical vibrations are usually found as an unwanted side effect in many areas of engineering. Examples include vehicle vibrations on uneven roads or engine vibrations. Vibration theory is a particularly challenging area in the field of mechanics.

The TM 150 vibration trainer can be used to study many topics from the field of vibration theory through experimentation.

The topics range from simple pendulum-swinging forced vibrations with resonance to vibration absorption.

The central element of the vibration trainer is a sturdy profile frame, to which the different experimental setups are easily attached. The extensive accessories are housed in a mobile laboratory table with drawers. In addition to free vibrations, forced vibrations can also be represented by means of an electric motor imbalance exciter. The excitation frequency is set and displayed on a control unit.

An oil damper allows the study of damped vibrations with adjustable damping ratios. Vibration absorbing is demonstrated with a tuneable bending oscillator. A mechanical drum and a polar chart recorder make it possible to record vibrations.

The measured values can be displayed and analysed on a PC using the optional TM 150.20 unit for data acquisition.

TM 150

Vibration trainer

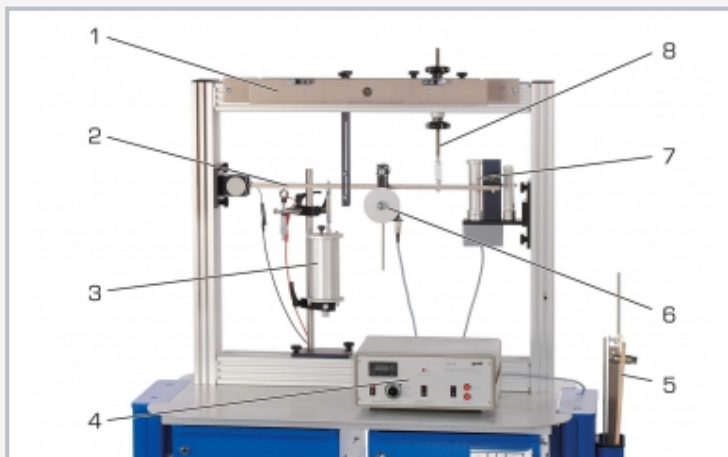

1 pendulum bearing, 2 bar-type oscillator, 3 container for oil damper, 4 control unit for imbalance exciter, 5 storage for additional pendulums, 6 imbalance exciter, 7 drum recorder, 8 spring

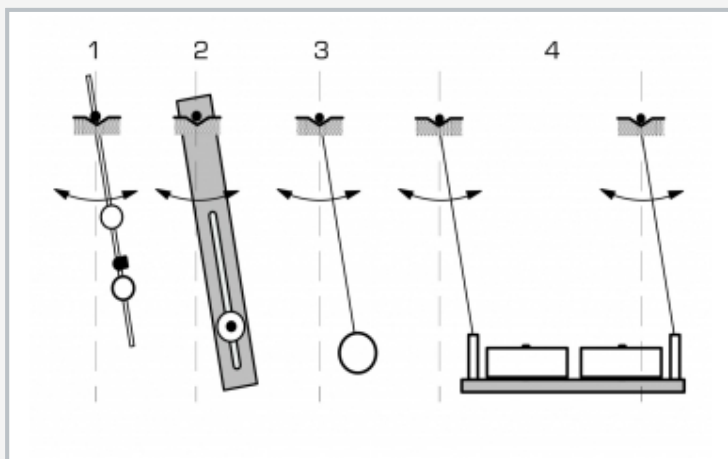

1 rod pendulum, 2 wooden pendulum with adjustable additional mass, 3 gravity pendulum, 4 bifilar suspended gravity pendulum with additional masses

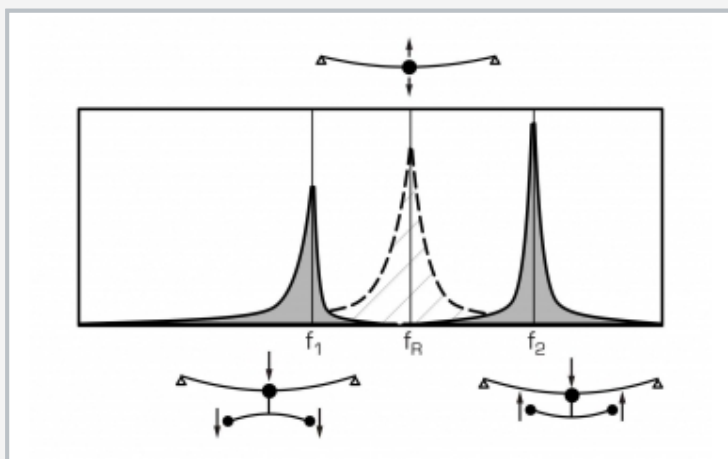

Absorber effect of additional masses:
The shaded area shows the resonance of an undisturbed bar-type oscillator at f_R .
The two grey shaded areas at f_1 and f_2 are the new resonances of the system.
At f_R , the amplitude of the newly occurring vibration system created by the absorber completely disappears.

Specification

- [1] vibration trainer with experiments on damping, resonance, dual-mass system and vibration absorption
- [2] 6 pendulum oscillators, 2 bar-type oscillators and 1 spring-mass oscillator
- [3] electrical imbalance exciter
- [4] control unit for the imbalance exciter with a digital frequency display and a TTL output for triggering external devices
- [5] tuneable absorber with a leaf spring
- [6] adjustable oil damper
- [7] electrically operated drum recorder for recording free vibrations
- [8] polar chart recorder for determining the amplitude and phase of forced vibrations

Technical data

Beam, rigid: LxWxH: 700x25x12mm, 1,6kg
 Beam, elastic: LxWxH: 25x4x700mm, 0,6kg
 Tension-pressure springs
 ■ 0,75N/mm
 ■ 1,5N/mm
 ■ 3,0N/mm

Imbalance exciter
 ■ 0...50Hz
 ■ 100cmg

Oil damper: 5...15Ns/m

Absorber
 ■ leaf spring: WxH: 20x1,5mm
 ■ total mass: approx. 1,1kg
 ■ tuneable: 5...50Hz

Drum recorder: 20mm/s, width 100mm
 Polar chart recorder: $\varnothing=100$ mm

230V, 50Hz, 1 phase
 230V, 60Hz, 1 phase; 120V, 60Hz, 1 phase
 UL/CSA optional
 LxWxH: 1010x760x1800mm
 Frame opening WxH: 870x650mm
 Weight: approx. 150kg

Scope of delivery

- 1 trainer
- 6 pendulums
- 2 beams
- 3 springs
- 1 control unit for imbalance exciter
- 1 imbalance exciter
- 1 oil damper
- 2 recorders
- 1 set of instructional material

TM 150

Vibration trainer

Universal vibration system

Optional accessories

040.15002

TM 150.02

Free and damped torsional vibrations

040.15020

TM 150.20

System for data acquisition