

TM 220

Belt drive and belt friction



Learning objectives/experiments

- effect of wrap angle, coefficient of friction and cable force (Eytelwein's belt friction formula)
- comparison of flat belts and V-belts
- consequences of an unadapted V-belt groove

Description

- function of a belt drive
- friction of different belt types on a metal pulley

The belt drives are machine elements that are classed as traction mechanisms in the field of transmission or conversion elements. They transfer torque and speed between guiding members such as wheels or pulleys. The motion is transferred by traction mechanisms that can only absorb tensile forces. Toothed belts and chains deliver positive transmission of movements. Traction mechanisms such as cables, flat belts and V-belts, on the contrary, allow for non-positive transmission.

In non-positive belt drives, the circumferential force between the belt and the pulley is transmitted according to the principle of cable friction.

Cable friction arises due to tangential static-friction forces at the points where the cable is in contact with the wheel or the pulley. Eytelwein's cable friction formula is used to calculate both cable and belt friction.

The TM 220 experimental unit allows the study by experiment of belt drives and belt friction. At the core of the experimental unit is a cast iron pulley, whose circumference features grooves for V-belts and flat belts. The pulley is mounted on ball bearings and is powered by a crank handle. Its flywheel mass favours an even rotation of the pulley. The belts rub on the pulley at a wrap angle between 30° and 180° . The wrap angle can be adjusted in increments of 15° .

Two spring balances detect the tensile forces on the respective belt ends. This makes it possible to precisely adjust the belt tension using a threaded spindle.

Two flat belts made of different materials, a V-belt and a cable belong to the scope of delivery. The experiments compare different belt types and materials and investigate the effect of the wrap angle.

In addition, for V-belts, it is possible to study how the groove shape affects the coefficient of friction.

TM 220

Belt drive and belt friction

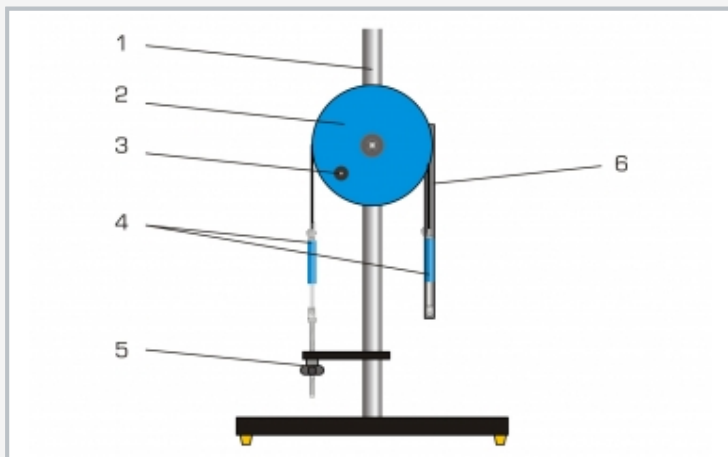

1 support column, 2 pulley, 3 crank handle, 4 spring balance, 5 belt tension adjustment, 6 pivoting belt holder

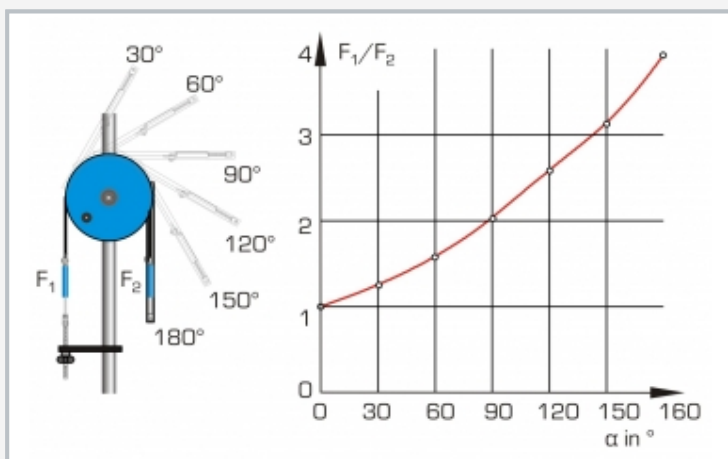

Gradual adjustment of the wrap angle from 30° to 180°. Diagram shows the force ratio F_1 / F_2 as a function of the wrap angle α .

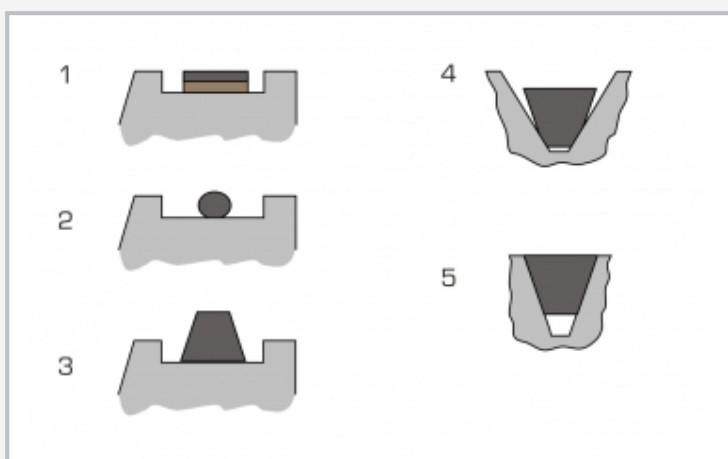

Comparison of different belt types: 1 flat belt, 2 cable, 3 V-belt, 4 adverse belt seat in the groove, 5 optimum belt seat in the groove

Specification

- [1] function of a belt drive
- [2] belt friction and comparison of different belt materials and types
- [3] ball-bearing mounted pulley with 3 different belt grooves
- [4] 2 flat belts made of different materials, 1 V-belt and 1 cable
- [5] wrap angle of the belts 30°...180°, graduation 15°
- [6] force measurement with 2 spring balances

Technical data

Flat belts

- 1x leather/polyamide, 15x2,2mm, Extremultus LT10
- 1x polyamide, 15x0,6mm, Extremultus TT2

V-belt

- ISO 4184
- profile: SPZ
- 9,7x8,0mm, rubber/fabric

Cable

- hemp, $\varnothing=3\text{mm}$

Pulley

- $\varnothing=300\text{mm}$
- material: grey iron
- Dynamometer: 100N $\pm 1\text{N}$

LxWxH: 700x350x1100mm

Weight: approx. 47kg

Scope of delivery

- 1 experimental unit
- 2 flat belts
- 1 cable
- 1 V-belt
- 2 dynamometers
- 1 set of instructional material

TM 220

Belt drive and belt friction

Optional accessories

020.30009 WP 300.09 Laboratory trolley