

# TM 260

## Drive unit for tribological investigations

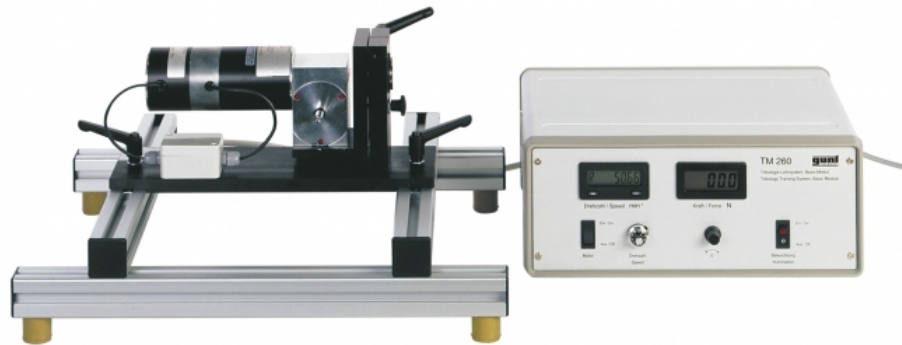

### Description

- **base module for studying various cases of sliding and rolling friction**
- **contact force by means of weights and lever**
- **electronic measurement of the frictional force between friction partners**

Tribology studies friction, wear and lubrication. Friction occurs when two solids are in contact with each other and their movement is impeded. If material is lost progressively during this process, it is referred to as wear. Lubricants are used to minimise friction and wear.

The TM 260 drive unit, together with the experimental units TM 260.01 to TM 260.06, offer a complete course with a series of experiments to study tribological phenomena. Various rolling and sliding cases can be demonstrated in the classroom or studied in the laboratory. The parameters of a tribological system are recorded and analysed. A comprehensive range of friction pairings makes it possible, among other things, to represent how the frictional force is independent of the contact area.

The TM 260 units comprise a frame on which the drive unit is mounted together with an experimental unit and a display and control unit. Quick-action chucks make it quick and easy to assemble. The drive unit has a pivotable motor block bearing. This allows the drive shaft to be installed horizontally or vertically. The speed of the DC motor is continuously adjustable and is detected by means of an incremental encoder. The frictional forces are measured by a force sensor in each experimental unit.

The display and control unit shows frictional force and speed, the latter of which can be adjusted continuously.

The following experiments can be conducted: Rolling friction in friction wheels (TM 260.01), Elasto-hydrodynamic behaviour (TM 260.02), Dynamic friction in a pin on a disk (TM 260.03), Frictional vibrations (TM 260.04), Dynamic friction in a cylindrical pin on a roller (TM 260.05), Pressure distribution in journal bearings (TM 260.06).

### Learning objectives/experiments

- together with the experimental units TM 260.01 to TM 260.06
  - ▶ rolling friction of two disks with slip
  - ▶ elasto-hydrodynamic behaviour (EHD theory) in rolling friction of a sphere against a flat surface
  - ▶ wear test: pin against disk
  - ▶ wear test: friction wheel experiment
  - ▶ frictional vibrations and slip-stick phenomenon
  - ▶ pressure distribution in the journal bearing

# TM 260

## Drive unit for tribological investigations

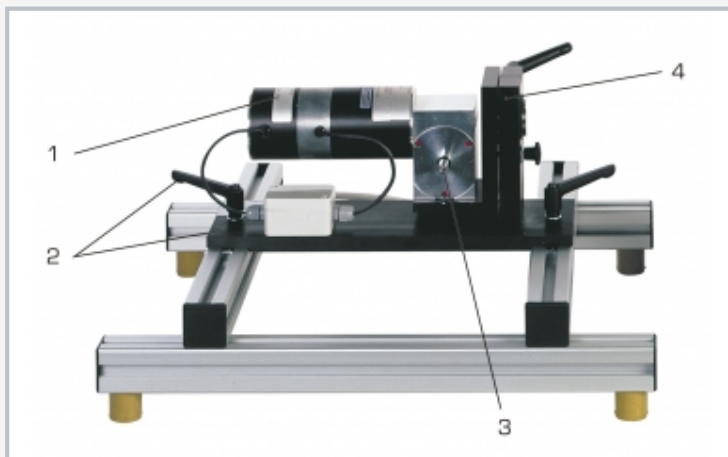

1 motor and gear, 2 quick-action chuck, 3 drive shaft, 4 pivotable drive

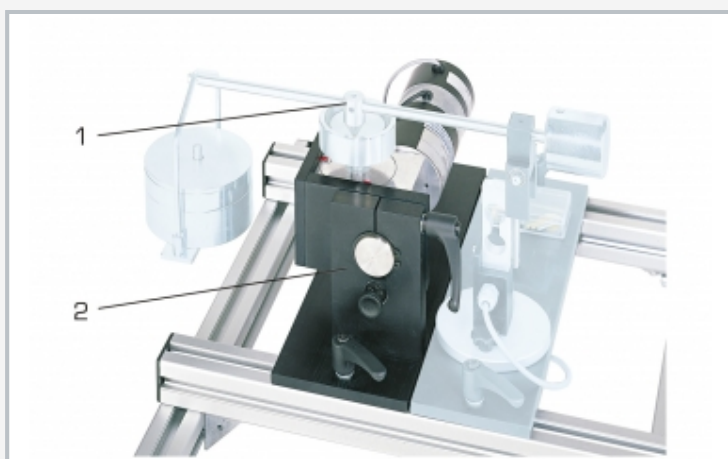

1 TM 260.03 experimental unit studies a tribological system, consisting of a pin and disk, which slide against each other, 2 TM 260 drive unit

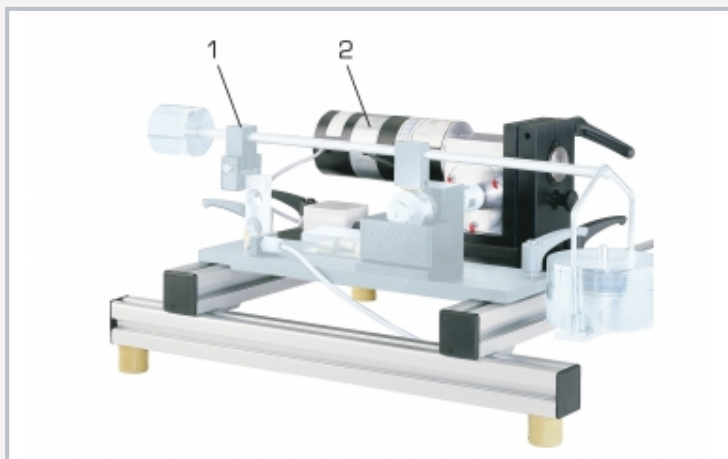

1 TM 260.05 experimental unit studies a tribological system, consisting of a cylindrical pin and a roller, which slide against each other (point contact), 2 TM 260 drive unit

### Specification

- [1] base module with drive unit and display and control unit for studying tribological phenomena
- [2] horizontal or vertical position of the drive shaft by means of pivotable motor block
- [3] various experimental units available as accessories
- [4] drive unit and experimental units secured by quick-action chucks
- [5] drive unit comprising DC motor with worm gear
- [6] speed of the DC motor is continuously adjustable
- [7] speed measured by incremental encoder
- [8] frictional force measured by force sensor
- [9] force and speed displayed on display and control unit

### Technical data

DC motor

- rated speed: 3000min<sup>-1</sup>
- torque: 18,5Nm

Worm gear: ratio 15:1

- operating speed: 0...200min<sup>-1</sup>, electronically controlled

Measuring ranges

- force: 0...50N
- speed: 0...200min<sup>-1</sup>

230V, 50Hz, 1 phase

230V, 60Hz, 1 phase; 120V, 60Hz, 1 phase

UL/CSA optional

LxWxH: 500x450x280mm (base module)

Weight: approx. 10kg

LxWxH: 360x330x170mm (display and control unit)

Weight: approx. 6kg

### Scope of delivery

- 1 base module
- 1 display and control unit
- 1 set of cables
- 1 set of instructional material

# TM 260

## Drive unit for tribological investigations

Tribology trainer base module

### Optional accessories

040.26001	TM 260.01	Rolling friction in friction wheels
040.26002	TM 260.02	Elasto-hydrodynamic behaviour
040.26003	TM 260.03	Dynamic friction in pin - disk
040.26004	TM 260.04	Frictional vibrations
040.26005	TM 260.05	Dynamic friction in cylindrical pin - roller
040.26006	TM 260.06	Pressure distribution in journal bearings
020.30009	WP 300.09	Laboratory trolley