

# TM 600

## Centrifugal force



### Description

#### ■ laws of the behaviour of rotating masses

Centrifugal force occurs in the motion of a rigid body on an orbit and is the inertia force, which acts with a direction away from the centre of rotation. The counterforce associated with the inertial force is the centripetal force. Both forces are of equal magnitude and opposite in direction. Centrifugal forces occur in all rotating machinery such as turbines and must be controlled to prevent damage to machine elements.

The TM 600 unit can be used to study centrifugal forces under various conditions. The core of the experimental unit is a rotating arm on a vertical rotation axis. Different masses are attached to the arm. The orbital radius can be set via the position of the mass on the arm. There are three different masses available. The occurring centrifugal force is transferred from the arm to a bending beam. The force-proportional deformation is detected via an electronic measuring system and displayed digitally.

The speed, also displayed digitally, of the controlled drive motor can be continuously adjusted. A transparent protective cover above the rotating arm ensures safety: operation is only possible when the protective cover is properly attached.

### Learning objectives/experiments

- investigation of the centrifugal force as a function of
  - ▶ the speed
  - ▶ the size of the rotating mass
  - ▶ the rotation radius

# TM 600

## Centrifugal force

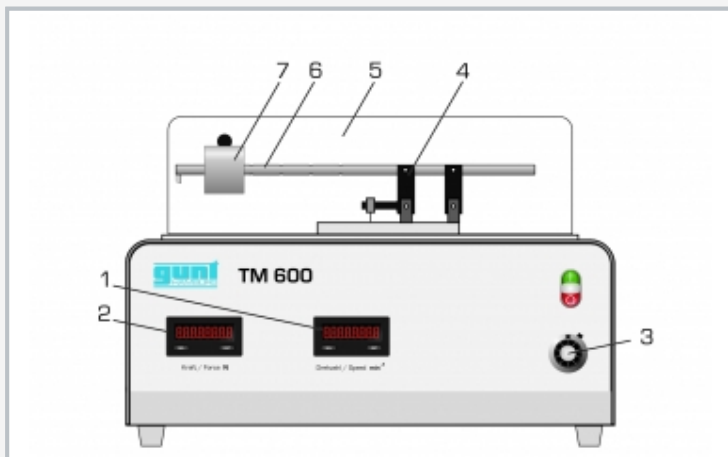

1 centrifugal force display, 2 speed display, 3 adjustment of the speed, 4 connecting rod (force measurement), 5 protective cover, 6 rotating arm, 7 mass

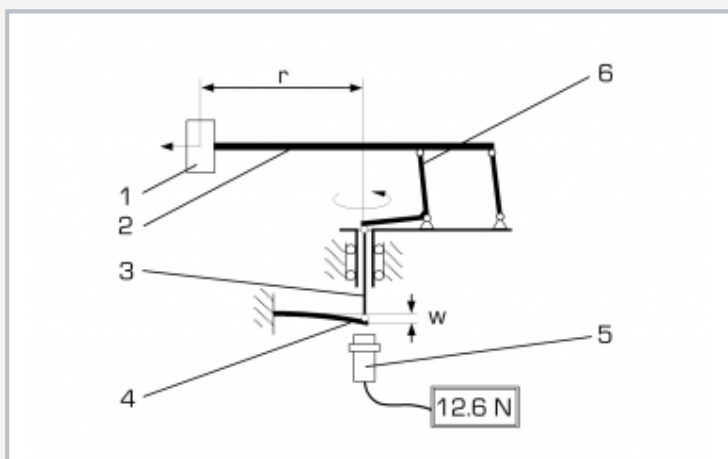

Principle of force measurement with force-proportional deformation:  
1 mass, 2 rotating arm, 3 member, 4 bending beam, 5 position sensor, 6 member;  
r radius, w deformation

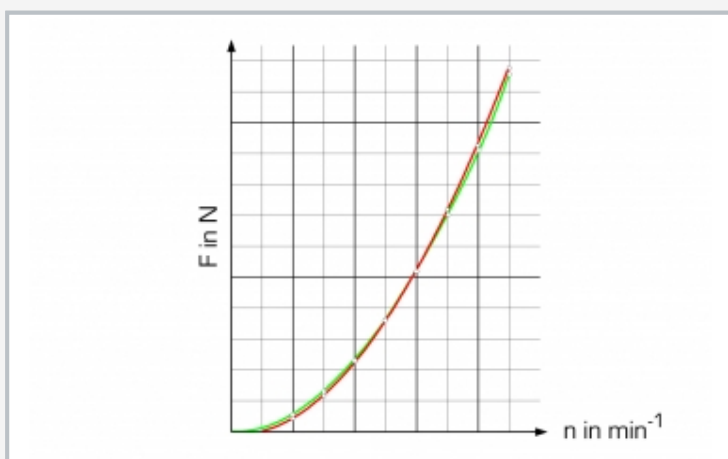

Dependence of centrifugal force on the speed green: calculated values, red: measured values; F centrifugal force, n speed

### Specification

- [1] measure the centrifugal force on rotating masses
- [2] adjustment of the orbital radii
- [3] selection of different masses
- [4] continuous adjustment of the speed
- [5] drive with DC motor
- [6] transmission of centrifugal force via the connecting rod and member to a bending beam
- [7] force-proportional deformation of the bending beam
- [8] measure the centrifugal force via an inductive position sensor on the bending beam
- [9] digital display of force and speed
- [10] protective cover with electronic coupling to the drive ensures safe operation

### Technical data

#### Orbit

- orbital radii: 25mm, 50mm, 75mm, 100mm, 125mm
- max. velocity: 6,5m/s

Masses: 50g, 75g, 100g

#### Drive motor

- max. power: 35W
- max. speed: 6000min<sup>-1</sup>

#### Measuring ranges

- speed: 0...500min<sup>-1</sup>
- force: 0...25N, resolution: 0,1N

230V, 50Hz, 1 phase

230V, 60Hz, 1 phase; 120V, 60Hz, 1 phase

UL/CSA optional

LxWxH: 420x400x270mm

Weight: approx. 23kg

### Scope of delivery

- 1 experimental unit
- 1 set of tools
- 1 set of weights
- 1 set of instructional material

# TM 600

## Centrifugal force

Centrifugal force apparatus

Optional accessories

020.30009

WP 300.09

Laboratory trolley