

# TZ 200.11

## Assembly of bending device

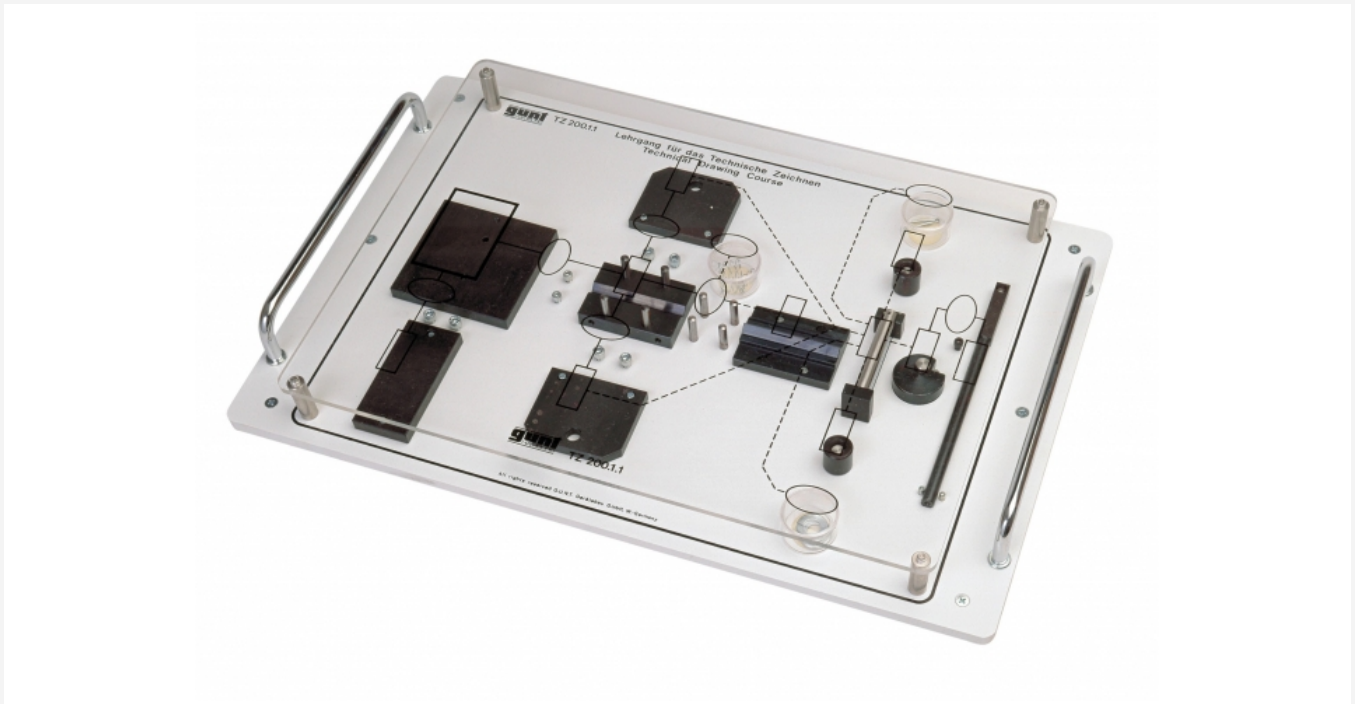

### Description

- GUNT course: engineering drawing
- bending device as assembly kit
- exercise for interdisciplinary teaching

A drawing is the most important means of information and communication in engineering. The ability to read and understand drawings, graphics and schematics is a fundamental element in the development of professional competence in all engineering disciplines. Linking engineering communication to the associated technical operations such as assembly structure, work plans and manufacturing is just as important.

The TZ 200.11 assembly kit is an interdisciplinary and practical project. In addition to the primary learning area of "engineering drawing", it is also possible to deal with topics such as assembly planning and execution as well as measuring exercises. The assembly kit includes all single parts required to assemble a functional bending device.

The parts are grouped on a base plate so that individual assembly sequences are clearly displayed. Above the base plate is a transparent cover plate with a graphical representation of the assembly structure. The graphic symbolizes standard and production parts and displays fixed and moving connections differently. All single parts and the corresponding drawings are available in a standards-compliant and practical form.

The manufactured parts are precision-manufactured from original materials and with common tolerances and surfaces. The surfaces of the manufactured parts are polished to prevent corrosion. All parts are clearly laid out and well protected in a storage system. Multiple storage systems can be stacked on top of each other, allowing space-saving storage.

Usage in the classroom should ideally be as a practical exercise, in which two or three students can work comfortably on one assembly kit.

### Learning objectives/experiments

- introduction to engineering drawing
  - ▶ read and understand engineering drawings
  - ▶ three-dimensional display
  - ▶ sectional views
  - ▶ drawing types
  - ▶ 3D representation
  - ▶ lists of parts
  - ▶ dimensioning
  - ▶ surface and tolerance specifications
  - ▶ difference between standard and production parts
  - ▶ materials specifications
- planning and execution of simple assembly operations
  - ▶ plan and describe operations
  - ▶ evaluate results
- measuring exercises
  - ▶ longitudinal measurements
  - ▶ angular measurements

# TZ 200.11

## Assembly of bending device

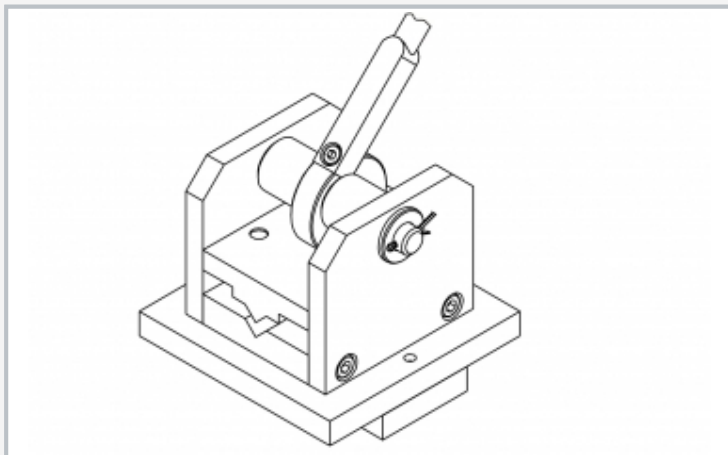

3D representation of the assembled bending device

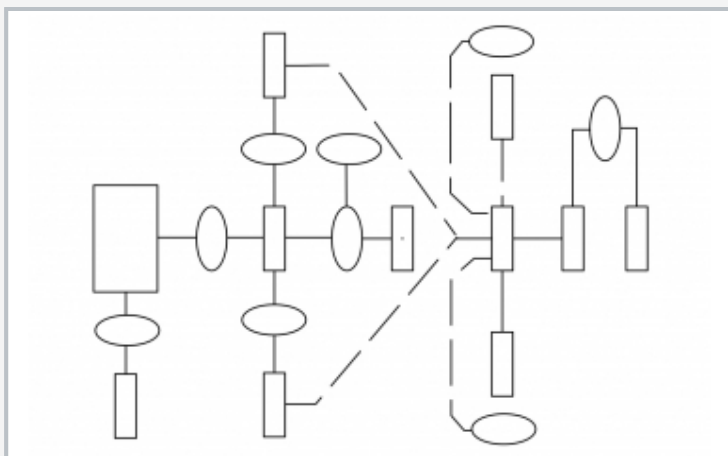

Graphical representation of the assembly structure

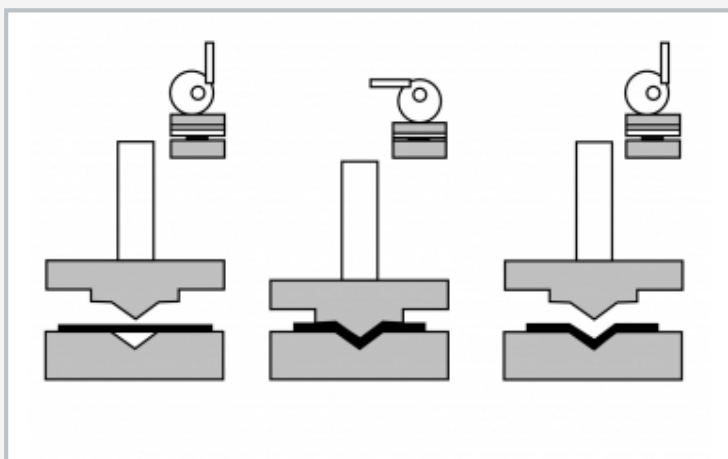

Bending process

### Specification

- [1] part of the GUNT course on engineering drawing
- [2] assembly kit of a functional bending device with eccentric operation
- [3] all production parts made from precision-manufactured burnished steel surfaces
- [4] assembly structure on transparent cover plate
- [5] storage system for parts
- [6] multiple storage systems can be stacked on top of each other
- [7] accompanying instructional material considers practical and interdisciplinary forms of teaching

### Technical data

LxWxH: 540x350x75mm (storage system)  
Weight: approx. 6kg

### Scope of delivery

- 1 storage system with the individual parts of the bending device
- 1 cover plate with assembly structure
- 1 set of tools for assembly and disassembly
- 1 set of instructional material