

# Temperature dependence of different resistors and diodes (Item No.: P2410401)

## Curricular Relevance

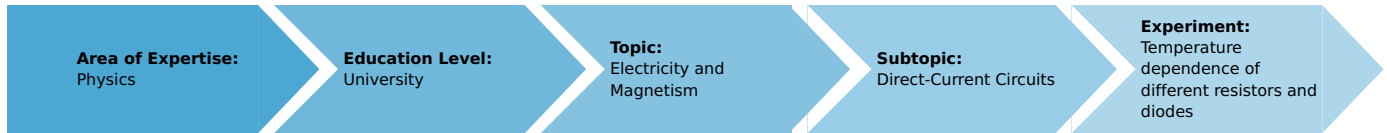

### Difficulty



Difficult

### Preparation Time



1 Hour

### Execution Time



3 Hours

### Recommended Group Size



2 Students

### Additional Requirements:

### Experiment Variations:

### Keywords:

carbon film resistor, metallic film resistor, PTC, NTC, Z diode, avalanche effect, Zener effect, charge carrier generation, free path, Mathies rule

## Overview

### Short description

The temperature dependence of an electrical parameter (e.g. resistance, conducting-state voltage, blocking voltage) of different components is determined. To do this, the immersion probe set is immersed in a water bath and the resistance is measured at regular temperature intervals.



Fig. 1: Experimental set-up.

## Equipment

Position No.	Material	Order No.	Quantity
1	PHYWE power supply DC: 0...12 V, 2 A / AC: 6 V, 12 V, 5 A	13505-93	1
2	Immersion thermostat Alpha A, 230 V	08493-93	1
3	External circulation set f. thermostat Alpha A	08493-02	1
4	Immersion probes for determining ct	07163-00	1
5	Bath for thermostat, makrolon	08487-02	1
6	Digital multimeter 2005	07129-00	1
7	Connection box	06030-23	1
8	Resistor 4.7 kOhm, 1W, G1	39104-27	1
9	Connecting cord, 32 A, 500 mm, blue	07361-04	1
10	Connecting cord, 32 A, 750 mm, red	07362-01	2
11	Connecting cord, 32 A, 750 mm, blue	07362-04	2
12	Tubing connector, ID 6-10mm	47516-01	2

## Tasks

1. Measurement of the temperature dependence of the resistance of different electrical components.
2. Measurement of the temperature dependence of the conducting state voltage of semiconducting diodes.
3. Measurement of the temperature dependence of the voltage in the Zener and the avalanche effects.

## Set-up and procedure

1. Place the immersion probe set, which is enclosed in a watertight plastic bag, into the water bath. The resistance values for the PTC, NTC, metallic film and carbon film resistors, as well as the Cu and CuNi wire resistors, can be measured directly with the digital hand multimeter (circuit diagram, Fig. 2). To do this, connect the multimeter to the ground jack, which is connected to all the components, and the jack located under the symbol corresponding to the respective component. Note the different resistance values, and plot them as a function of temperature.

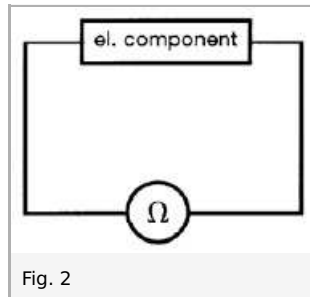

2. In order to measure the conducting-state voltage of the semiconducting diodes, connect them to a voltage of 10 V. Connect a  $4.7\Omega$  resistor in series with the component. Set a voltage of 10 V on the universal power supply, and adjust the current limiter to its maximum value. Measure the voltage parallel to the component. Note the conducting-state voltage corresponding to the respective temperatures.

3. Also measure the blocking voltage for the Zener and avalanche effects with the set-up illustrated in Fig. 3. However, the diodes have already been wired in the blocking direction through their placement in the immersion probe set.

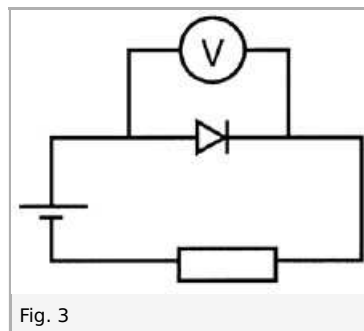

## Theory and evaluation

In restricted temperature ranges the change in the resistance of the electrical components can be assumed to be linear. In these regions, the general formula for the dependence of the resistance on the temperature is valid

$$R(T) = R_{20} + R_{20} \cdot \alpha \cdot (T - 20 \text{ }^\circ\text{C})$$

where  $R(T)$  = Resistance at temperature  $T$

$R_{20}$  = Resistance at 20 °C

$\alpha$  = Temperature coefficient

$T$  = Temperature at time of measurement

By rearranging and substituting the measured values the temperature coefficient can be determined using the formula.

1. In copper wire the free path of the electrons in the electron vapour, which contribute to charge transport, becomes shorter with increasing temperature. The change in resistance can be clearly seen: the resistance increases. The result is a positive temperature coefficient

$$\alpha_{\text{Cu}} = 5.3 \cdot 10^{-3} / \text{K}$$

The resistance of the CuNi wire is nearly constant over the measured range. This is in accordance with Mathies rule, which states that  $R_{tot} = R_{20} + R(T)$ . The change in the resistance with the temperature is very slight in the measured temperature range. Consequently, the absolute resistance ( $R_{20}$ ) is predominant. This experiment provides a negative temperature coefficient of  $\alpha_{CuNi} = -1.4 \cdot 10^{-4}/K$

In the carbon-layer resistor, the absolute resistance is very high to begin with. The change with the temperature is, as is the case with CuNi, small and has practically no effect. A negative temperature coefficient results

$$\alpha_C = -2.3 \cdot 10^{-3}/K$$

The metallic layer resistor also has a relatively high absolute resistance at 20 °C. And the change in the measured temperature range is even lower than for carbon. Thus, the temperature coefficient approaches zero.

$$\alpha_{met} \Rightarrow 0$$

The two NTC and PTC resistors consist of alloys. Depending on their compositions, great changes in resistance can be realised in a small temperature range. The curves that are recorded in this experiment can no longer be considered linear. They serve only to illustrate the behaviour of NTC and PTC resistors.

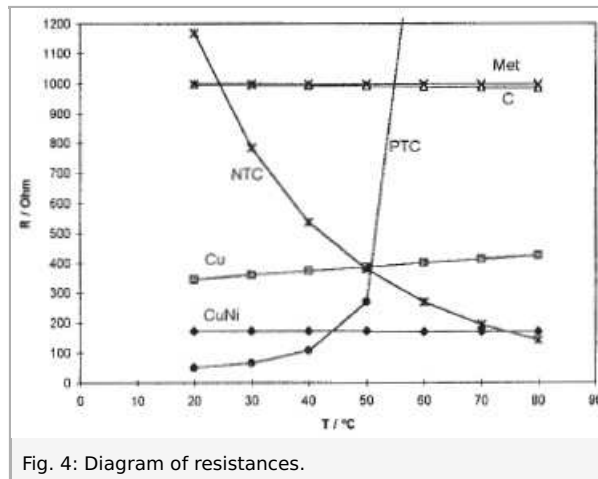

Fig. 4: Diagram of resistances.

Literature values:

$$\alpha_{Cu} = 4.0 \cdot 10^{-3}/K$$

$$\alpha_{CuNi} = -3.0 \cdot 10^{-3}/K$$

$$\alpha_C = -2.4 \cdot 10^{-4}/K$$

$$\alpha_{met} = \pm 0 \dots 50 \cdot 10^{-6}/K$$

$$\alpha_{NTC} = -6.15\%/K$$

$$\alpha_{PTC} = 20\%/K$$

The value for PTC is valid in the steepest region of the characteristic line.

2. In semiconductors the number of charge carriers and the charge carrier density increases with temperature (charge carrier generation, electron-hole pair formation). From the law

$$\sigma = e \cdot n \cdot \mu$$

where

$\sigma$  = Intrinsic conductivity

$e$  = Elementary charge

$n$  = Charge carrier density

$\mu$  = Mobility

one can see that the intrinsic conductivity of the semiconductor thus increases. The mobility indeed decreases with increasing temperature, but the increase in the charge carrier density compensates for this effect. A definite drop in resistance is observed; this allows one to infer that there is a negative temperature coefficient. Through the calculation with the above-mentioned formula for the temperature dependence, rearranged for the voltage  $U_p$ , the following values are obtained.

$$\alpha_{Si} = -3.4 \cdot 10^{-3} / K$$

$$\alpha_{Ge} = -4.6 \cdot 10^{-3} / K$$

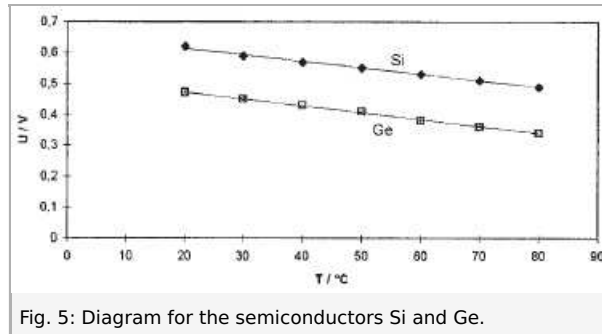

3. At low voltages, around 3 V, a Zener breakdown occurs in Z diodes. As a result of the strong electric field, electron-hole pairs are spontaneously generated in the inner electron shells in the barrier-layer zone. Under the influence of the field charge carrier, they cross the barrier layer. A higher temperature increases the energy of the bound charge carriers. As a consequence, the Zener effect can occur at lower voltages. In the avalanche effect, the charge carriers are accelerated by the electric field to such a great degree that they in turn release other charge carriers on colliding with other atoms, which in turn are accelerated. The higher temperature shortens the free path, so that the voltage must increase with the temperature in order to continue to release charge carriers. From the calculations, the following values result for  $\alpha$  :

$$\alpha_{ZPD2.7} = -7.3 \cdot 10^{-4} / K$$

$$\alpha_{ZPD6.8} = +4.5 \cdot 10^{-4} / K$$

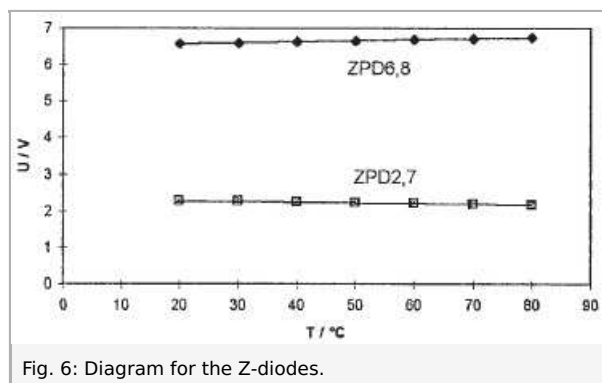

Literature values:

$$\alpha_{ZPD2.7} = -9 \dots -4 \cdot 10^{-4} / K$$

$$\alpha_{ZPD6.8} = +2 \dots +7 \cdot 10^{-4} / K$$