

WL 110.02

Plate heat exchanger



Description

■ plate heat exchanger for connection to WL 110 supply unit

The key feature of plate heat exchangers is their compact design, in which optimum use is made of all of the material for heat transfer. The pressed in profile on the plates creates narrow flow channels, in which significant turbulence occurs. The turbulent flow allows effective heat transfer even with low flow rates and also has a self-cleaning effect. Plate heat exchangers are used in the food industry, offshore technology, refrigeration and domestic engineering.

The WL 110.02 is part of a series of units enabling experiments to be performed on different heat exchanger types. The experimental unit is ideally suited for investigating the functioning and behaviour of a plate heat exchanger in operation.

The WL 110.02 is connected to the supply unit WL 110 using quick-release couplings. The plate heat exchanger is made up of profiled plates with water flowing through the spaces between them. The plates are soldered in such a way that two separate flow channels are formed. These are one "cold" and one "hot" flow channel, in an alternating arrangement. Part of the thermal energy

of the hot water is transferred to the cold water. Valves on the supply unit are used to adjust the flow rates of hot and cold water. The supply hose can be re-connected using quick-release couplings, allowing the flow direction to be reversed. This allows parallel flow or counterflow operation. The temperature sensors for measuring the inlet and outlet temperature are located at the supply connections on the WL 110.

During experiments, temperature curves are plotted and displayed graphically. Additionally, the measured values can be recorded and processed using data acquisition software. The mean heat transfer coefficient is then calculated as a characteristic variable.

Learning objectives/experiments

- in conjunction with WL 110 supply unit
 - ▶ function and behaviour during operation of a plate heat exchanger
 - ▶ plotting temperature curves:
 - in parallel flow operation
 - in counterflow operation
 - ▶ calculation of mean heat transfer coefficient
 - ▶ comparison with other heat exchanger types

WL 110.02

Plate heat exchanger

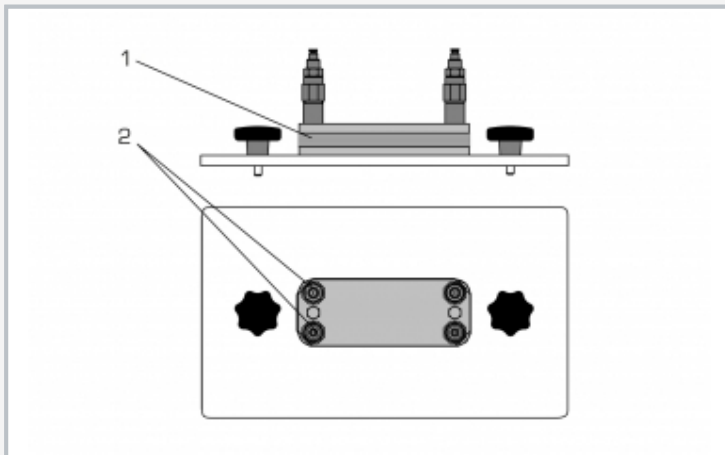

1 plates, 2 water connections

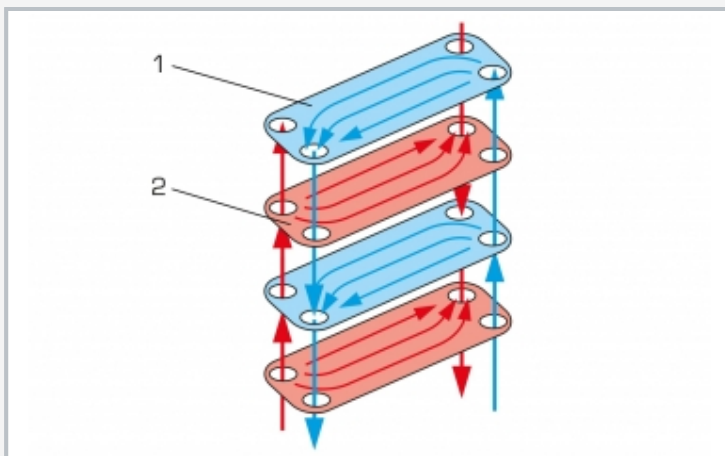

1 plate with cold water, 2 plate with hot water; red: hot water, blue: cold water

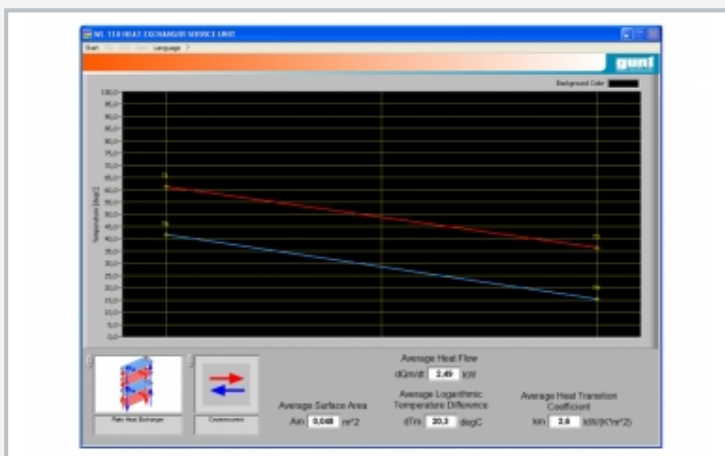

Software screenshot: temperature curve in counterflow operation

Specification

- [1] plate heat exchanger for connection to WL 110
- [2] hot and cold water supply from WL 110
- [3] parallel flow and counterflow operation possible
- [4] six soldered plates
- [5] recording of temperature using WL 110

Technical data

6 plates, stainless steel
Heat transfer area: 480cm²

LxWxH: 400x230x85mm
Weight: approx. 3kg

Scope of delivery

- 1 plate heat exchanger

WL 110.02

Plate heat exchanger

Required accessories

060.11000 WL 110 Heat exchanger supply unit