

WL 110.03

Shell & tube heat exchanger



Description

- shell and tube heat exchanger for connection to WL 110 supply unit
- media flowing in cross-flow

Shell and tube heat exchangers are in widespread use. The main advantages of this design are the large heat transfer area and the compact design. Shell and tube heat exchangers are used in the chemical and pharmaceutical industries, in refineries and in process engineering plants.

The WL 110.03 is part of a series of units enabling experiments to be performed on different heat exchanger types. The experimental unit is ideally suited for investigating the functioning and behaviour of a shell and tube heat exchanger in operation.

The WL 110.03 is connected to supply unit WL 110 using quick-release couplings. The shell and tube heat exchanger consists of seven tubes, surrounded by a transparent outer shell. The hot water flows through the tube space and the cold water through the space in the shell. Part of the thermal energy of the hot water is transferred to the cold water. Baffle plates are used to deflect the flow in the shell in such a way as to create greater turbulence and thus a more

intensive transfer of heat. The media flows in a cross-flow. Valves on the supply unit are used to adjust the flow rates of hot and cold water. The supply hose can be reconnected using quick-release couplings, allowing the flow direction to be reversed. This allows cross parallel flow or cross counterflow operation. Temperature sensors for measuring the inlet and outlet temperature are located at the supply connections on the WL 110.

During experiments, temperature curves are plotted and displayed graphically. Additionally, the measured values can be recorded and processed using data acquisition software. The mean heat transfer coefficient is then calculated as a characteristic variable.

Learning objectives/experiments

- in conjunction with WL 110 supply unit
 - ▶ function and behaviour during operation of shell and tube heat exchanger
 - ▶ plotting temperature curves:
 - in cross parallel flow operation
 - in cross counterflow operation
 - ▶ calculation of mean heat transfer coefficient
 - ▶ comparison with other heat exchanger types

WL 110.03

Shell & tube heat exchanger

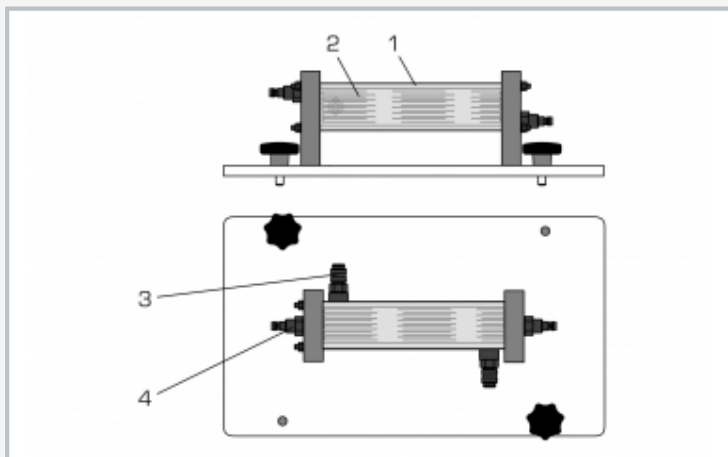

1 transparent shell, 2 tube bundle, 3 shell water connection, 4 tube bundle water connection

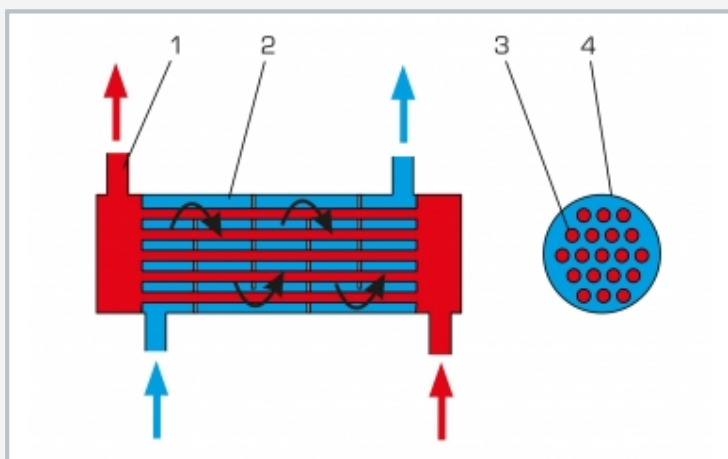

1 hot water, 2 cold water, 3 tube, 4 shell; red: hot water, blue: cold water



Software screenshot: temperature curve in cross parallel flow operation

Specification

- [1] shell and tube heat exchanger (cross-flow) for connection to WL 110
- [2] hot and cold water supply from WL 110
- [3] cross parallel flow and cross counterflow operation possible
- [4] transparent shell, visible tube bundle
- [5] tube bundle consisting of 7 tubes and 4 baffle plates
- [6] recording of temperature using WL 110

Technical data

Heat transfer area: 200cm²
 Tube bundle, stainless steel
 ■ outer diameter: 6mm
 ■ wall thickness: 1mm
 ■ tubes, 7

Shell, transparent (PMMA)
 ■ outer diameter: 50mm
 ■ wall thickness: 3mm

LxWxH: 400x230x110mm
 Weight: approx. 3kg

Scope of delivery

- 1 shell and tube heat exchanger

WL 110.03

Shell & tube heat exchanger

Required accessories

060.11000	WL 110	Heat exchanger supply unit
-----------	--------	----------------------------