

WP 140

Fatigue strength test



Description

- different specimens show the influence of notching and surface quality
- continuous adjustment of the load amplitude
- automatically shuts down when the specimen fractures

Moving components and machine parts are often exposed to periodically fluctuating loads. Even if the dynamic load is far below the static load capacity, this load can lead to fracture of the component after a long time because of material fatigue. The fatigue strength and design strength of components are determined in fatigue strength tests or endurance tests.

The WP 140 trainer demonstrates the basic principles of fatigue strength testing and the creation of a Wöhler diagram. The clean layout and simple operation mean the experimental sequence can be observed in all details and phases. In the experiment, a cantilever-mounted and rotating cylindrical specimen is subjected to a single force. The load on the specimen corresponds to a cantilever bending beam. The specimen is subjected to a pure reverse bending stress and breaks after a certain number of load cycles because of material fatigue.

The necessary force is generated in the load application device by means of a spring balance and a movable support. The load amplitude can be adjusted continuously using the preload of the spring balance by means of a threaded spindle. An electronic counter registers the number of load cycles and displays it digitally. The impulse for the counter is provided by an inductive proximity switch on the motor coupling. The counter can also be used to measure the speed.

When the specimen breaks, the stop switch stops the electric motor automatically. A protective cover protects against flying fragments.

Specimens with various fillet radii are included in the scope of delivery to demonstrate the notching effect and the influence of the surfaces.

By using the WP 140.20 system for data acquisition, the measured values can be transferred to a PC where they can be analysed with the software.

Learning objectives/experiments

- fatigue strength of bars under reverse bending stress
- influence of different fillet radii and surface qualities on the fatigue strength
- Wöhler diagram

WP 140

Fatigue strength test



1 protective cover, 2 electric motor, 3 switch box, 4 tool, 5 specimens, 6 bearing, 7 clamped specimen, 8 load application device with spring balance and hand wheel

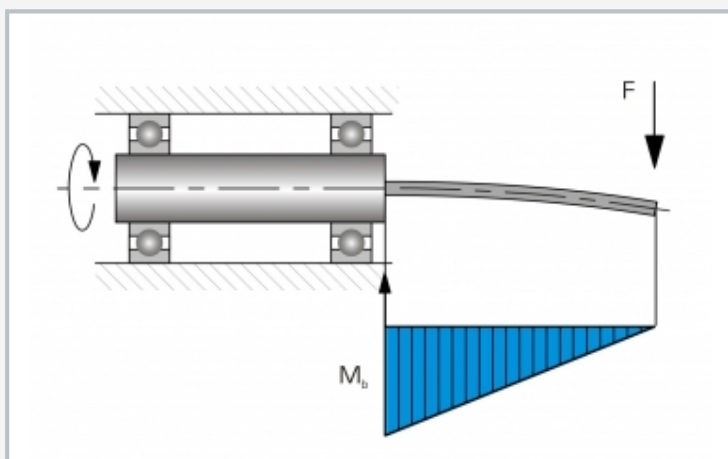

Functional principle of a fatigue strength test: cantilever mounted rotating specimen, loaded with a single force; F force, M_b bending moment

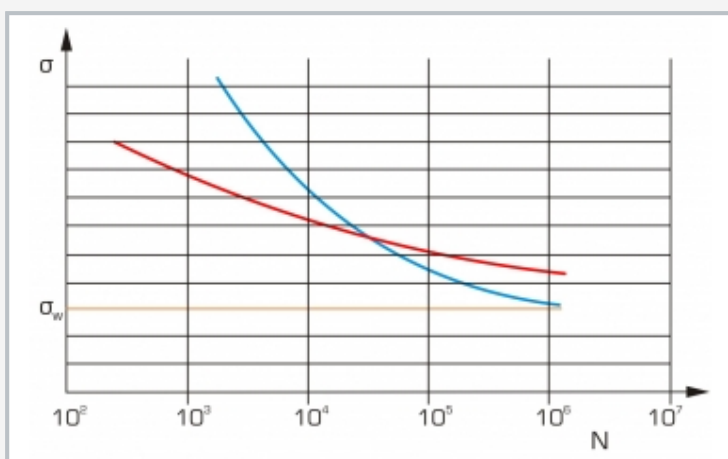

Woehler diagram for two different materials N : number of load cycles, σ : stress load on the specimen

With increasing number of cycles, the permissible load of a material asymptotically approaches the fatigue strength σ_w .

Specification

- [1] basic principles of fatigue strength testing
- [2] driven by electric motor
- [3] automatically shuts down when the specimen fractures
- [4] load application device with sliding movable support, threaded spindle with hand wheel, spring balance
- [5] steel cylindrical specimens, various fillet radii
- [6] speed measured by contactless inductive speed sensor or electronic counter for load cycles
- [7] digital counter display
- [8] protective cover for safe operation
- [9] system for data acquisition (WP 140.20) available as an option

Technical data

Electric motor

- speed: 2800 min^{-1}
- power: $0,37 \text{ kW}$

Load force

- $0 \dots 300 \text{ N}$

Electronic load counter

- 8-digit
- switchable to indicate speed

Specimens

- material: steel Ck35
- 3 different fillet radii

230V, 50Hz, 1 phase

230V, 60Hz, 1 phase; 120V, 60Hz, 1 phase

UL/CSA optional

LxWxH: $840 \times 410 \times 600 \text{ mm}$

Weight: approx. 31 kg

Scope of delivery

- 1 experimental unit
- 1 set of specimens (9 piece)
- 1 set of instructional material

WP 140

Fatigue strength test

Fatigue testing machine

Optional accessories

| | | |
|-----------|-----------|--|
| 020.14001 | WP 140.01 | Set of 3 specimens, various fillet radii, St |
| 020.14020 | WP 140.20 | Data acquisition system |
| 020.30009 | WP 300.09 | Laboratory trolley |