

Peltier heat pump (Item No.: P2410800)

Curricular Relevance

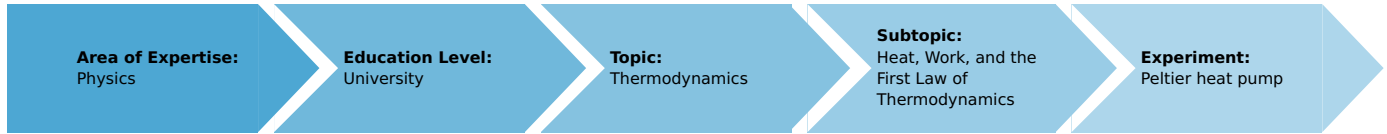

Difficulty



Difficult

Preparation Time



20 Minutes

Execution Time



20 Minutes

Recommended Group Size



1 Student

Additional Requirements:

Experiment Variations:

Keywords:

Peltier effect, heat pipe, thermoelectric e.m.f., Peltier coefficient, cooling capacity, heating capacity, efficiency rating, Thomson coefficient, Seebeck coefficient, Thomson equations, heat conduction, convection, forced cooling, Joule effect

Introduction

Overview

The cooling capacity, heating capacity and efficiency rating of a Peltier heat pump are determined under different operating conditions.

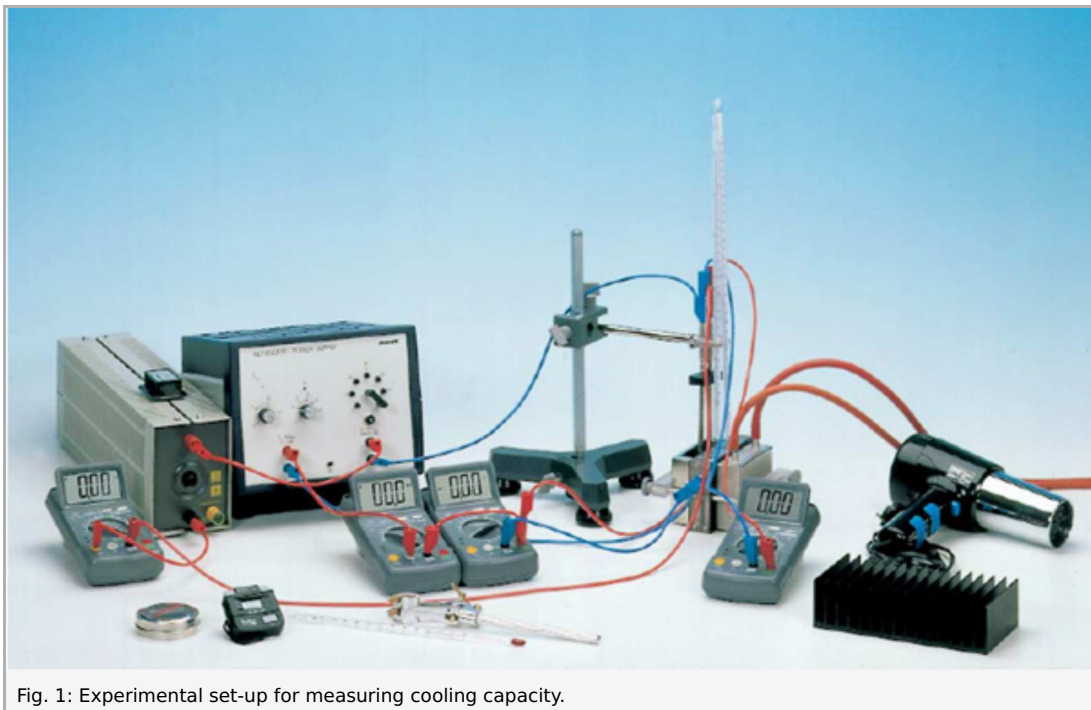

Fig. 1: Experimental set-up for measuring cooling capacity.

Equipment

Position No.	Material	Order No.	Quantity
1	Thermogenerator with 2 water baths	04366-00	1
2	Flow-through heat exchanger	04366-01	1
3	Air cooler	04366-02	1
4	Heating coil with sockets	04450-00	1
5	Distributor	06024-00	1
6	Rheostat, 33 Ohm , 3.1A	06112-02	1
7	Connecting plug, 2 pcs.	07278-05	1
8	PHYWE power supply, universal DC: 0...18 V, 0...5 A / AC: 2/4/6/8/10/12/15 V, 5 A	13500-93	1
9	Digital multimeter 2005	07129-00	4
10	Stopwatch, digital, 1/100 s	03071-01	1
11	Hot/cold air blower, 1800 W	04030-93	1
12	Lab thermometer,-10..+100 °C	38056-00	1
13	Thermometer -10...+50 °C	38034-00	2
14	Rubber tubing, i.d. 6 mm	39282-00	1
15	Universal clamp	37715-00	1
16	Tripod base PHYWE	02002-55	1
17	Support rod PHYWE,square,l 250mm	02025-55	1
18	Right angle clamp expert	02054-00	1
19	Connecting cord, 32 A, 250 mm, red	07360-01	3
20	Connecting cord, 32 A, 500 mm, red	07361-01	3
21	Connecting cord, 32 A, 500 mm, blue	07361-04	2
22	Connecting cord, 32 A, 750 mm, blue	07362-04	2
23	Connecting cord, 32 A, 750 mm, red	07362-01	1
24	Heat conductive paste,50 g	03747-00	1

Tasks

1. To determine the cooling capacity P_C the pump as a function of the current and to calculate the efficiency rating η_C at maximum output.
2. To determine the heating capacity P_W of the pump and its efficiency rating η_W at constant current and constant temperature on the cold side.
3. To determine P_W , η_W and P_C , η_C from the relationship between temperature and time on the hot and cold sides.
4. To investigate the temperature behaviour when the pump is used for cooling, with the hot side air-cooled.

Set-up and procedure

1. Fit a water bath on the cold side and a heat exchanger through which tap water flows on the hot side. A heating coil (resistance approx. 3 ohms), operated on AC, dips into the water-filled bath. For each current value I_P set the heating capacity $P_H = U_H \cdot I_H$ with the rheostat R so that the temperature difference between the hot and the cold side is approximately zero. The power supplied then exactly corresponds to the cooling capacity P_C . Measure the heater current I_H and voltage U_H , the operating current I_P and voltage U_P and the temperatures of the hot side T_h and the cold side T_c .
2. Remove the heating coil as it is no longer required. Reverse the operating current so that the water in the bath now heats up. Measure the rise in the temperature of water T_W at constant current I_P . Measure also I_P , U_P and T_C . Calculate the heat capacities of a copper block C_{cu} , of the water C_W and of the brass bath C_{Br} from their dimensions or by weighing.
3. Fit water baths to both sides of the heat pump and fill them with water of the same temperature. With the current I_P constant) measure the changes in the temperature of the two water baths) i. e. $T_h = f(t)$, $T_c = f(t)$, I_P and U_P .
4. For this fourth experiment we have a water bath on the cold side, an air cooler on the hot. Measure the temperature of the cold side as a function of time, with the cooler
 - a) in static atmospheric air, and
 - b) force-cooled with a blower.

Theory and evaluation

When an electric current flows through a circuit composed of two different conductors, heat will be liberated at one junction and absorbed at the other) depending on the direction in which the current is flowing (Peltier effect). The quantity of heat Q liberated per unit time is proportional to the current I :

$$\frac{Q}{t} = P_p = \pi \cdot I = \alpha \cdot T \cdot I$$

where π is the Peltier coefficient, α the Seebeck coefficient and T the absolute temperature. If an electric current I flows in a homogeneous conductor in the direction of a temperature gradient

$$\frac{dT}{dx}$$

heat will be absorbed or given out, depending on the material (Thomson effect):

$$P_T = \tau \cdot I \cdot \frac{dT}{dx}$$

where τ is the Thomson coefficient.

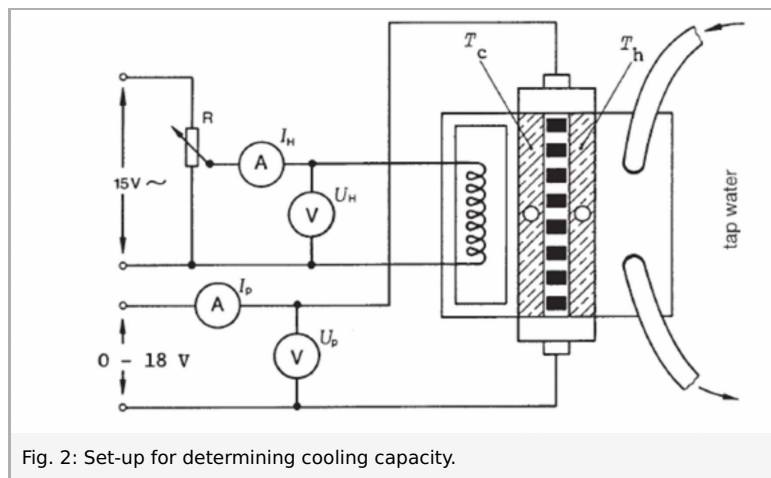

Fig. 2: Set-up for determining cooling capacity.

The direction in which the heat flows depends on the sign of the Thomson coefficient, the direction in which the current flows and the direction of the temperature gradient.

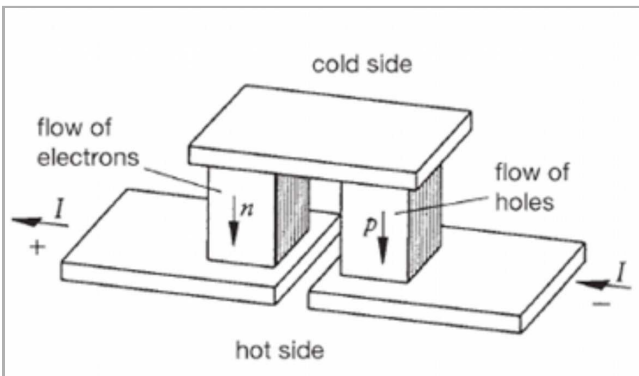

Fig. 3: Construction of a Peltier semi-conductor element. In practice several elements are generally connected in series (electrically) and in parallel (thermally).

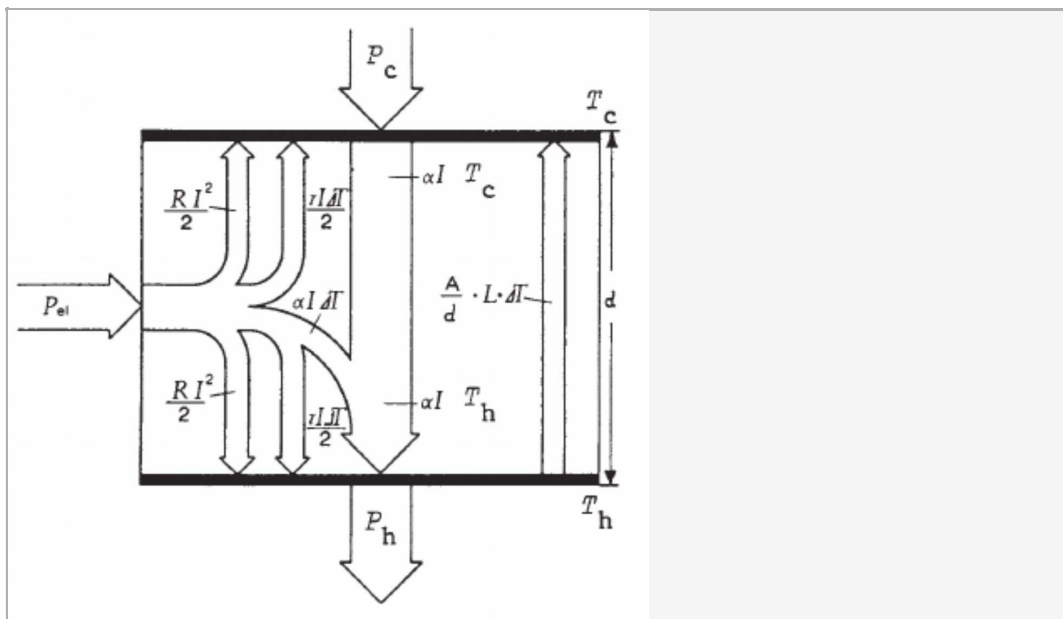

Fig. 4: Power balance flow chart in a Peltier component. (The example illustrated is for the case where $P_T > 0$).

If an electric current I flows in an isothermal conductor of resistance R , we have the Joule effect:

$$P_J = R \cdot I^2$$

Because of heat conduction, heat also flows from the hot side (temperature T_h) to the cold side (temperature T_c):

$$P_L = L \frac{A}{d} (T_h - T_c)$$

where L is the conductivity, A the cross-sectional area and d the thickness of the Peltier component. Writing $\Delta T = T_h - T_c$, we obtain for the heat capacity of the pump on the cold side (the cooling capacity):

$$-P_c = \alpha T_c I \pm \frac{\tau I \Delta T}{2d} - \frac{1}{2} I^2 R - \frac{L \cdot A \cdot \Delta T}{d}$$

and, for the heat capacity of the pump on the hot side (the heating capacity):

$$+P_h = \alpha T_h I \pm \frac{\tau I \Delta T}{2d} - \frac{1}{2} I^2 R - \frac{L \cdot A \cdot \Delta T}{d}$$

The electric power supplied is

$$+P_{el} = \alpha \Delta T I + \frac{\tau I \Delta T}{2d} - I^2 R = U_p \cdot I_p$$

1. The pump cooling capacity P_C was found to be 49 W when $I_p = 5A$ and $P_h = P_C$
The efficiency rating

$$\eta_c = \frac{P_c}{P_{el}}$$

becomes, for the measured values

$$I_p = 5.0 \text{ A and } U_p = 14.2 \text{ V, } \eta_c = 0.69 (\vartheta_h = \vartheta_c = 20) \text{ } ^\circ\text{C}$$

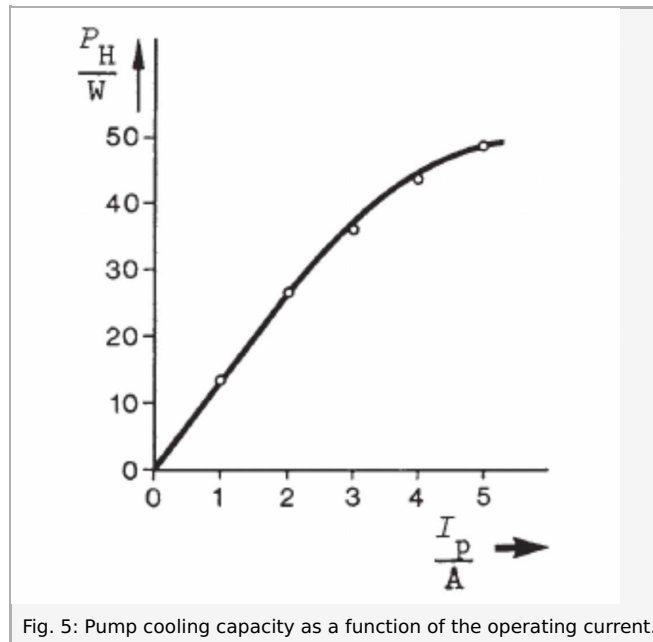

Fig. 5: Pump cooling capacity as a function of the operating current.

2. From the slope of the curve in Fig. 6 (where the curve starts off as a straight line) we can calculate the pump heating capacity

$$P_h = \frac{C_{tot} \Delta T_h}{\Delta T}$$

and the corresponding efficiency rating

$$\eta_h = \frac{P_h}{P_{el}}$$

Where $P_{el} = I_p \cdot U_p$
as follows:

$$m_W = 0.194 \text{ Kg} \quad c_W = 4182 \frac{\text{J}}{\text{kg K}}$$

$$m_{Br} = 0.0983 \text{ Kg} \quad c_{Br} = 381 \frac{\text{J}}{\text{kg K}}$$

$$m_{Cu} = 0.712 \text{ Kg} \quad c_{Cu} = 383 \frac{\text{J}}{\text{kg K}}$$

$$C_{tot} = m_W \cdot c_W + m_{Br} \cdot c_{Br} + m_{Cu} \cdot c_{Cu} = 1121 \frac{\text{J}}{\text{kg K}}$$

where m_W is the mass of the water, c_W the specific heat capacity of the water, m_{Cu} the mass of a copper block, c_{Cu} the specific heat capacity of copper, m_{Br} the mass of the brass bath, c_{Br} the specific heat capacity of brass, I_p the pump current, and the mean pump voltage.

With the slope

$$\frac{\Delta T_h}{\Delta T} = 6.7 \times 10^{-2} \text{ K/s}$$

We obtain a value P_h of 75 W.

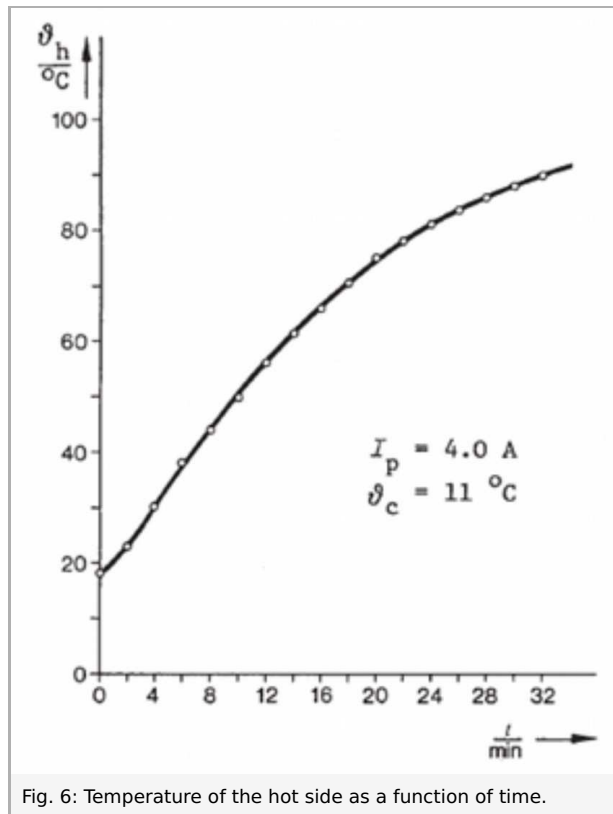

Fig. 6: Temperature of the hot side as a function of time.

With values for I_p of 4.0 A and U_P of 12.5 V (average value) we obtain an efficiency rating $\eta_C = 1.5$

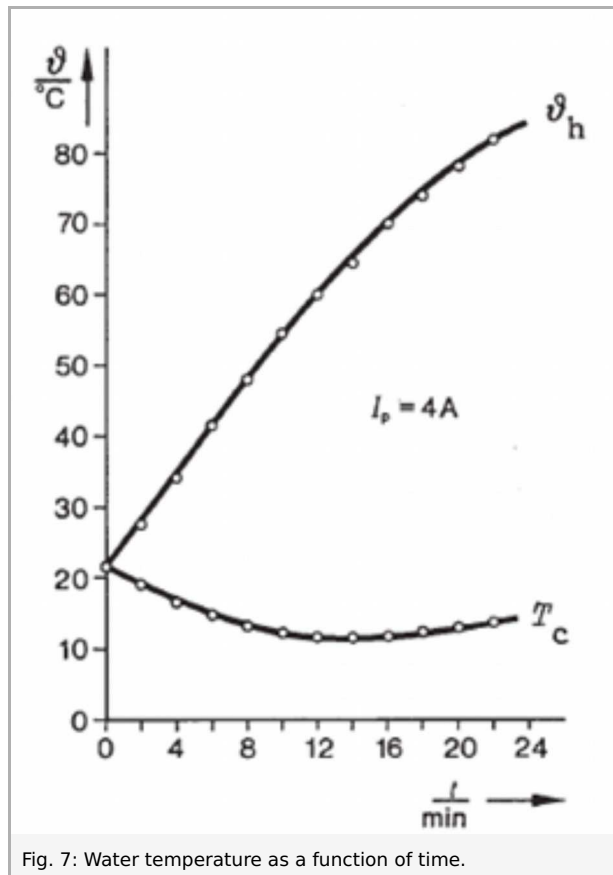

Fig. 7: Water temperature as a function of time.

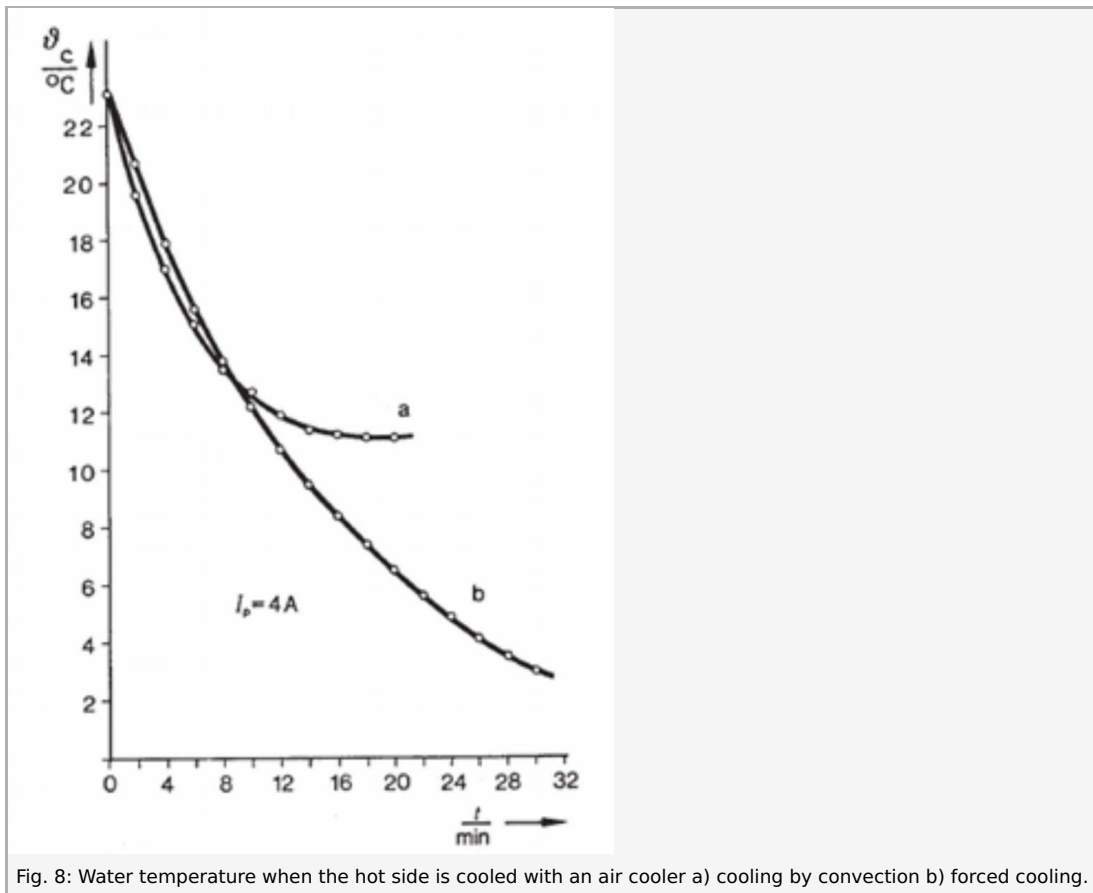

Fig. 8: Water temperature when the hot side is cooled with an air cooler a) cooling by convection b) forced cooling.

3. P_h and P_c , and η_h and η_c , can be calculated from the slopes of the curves $\vartheta_h = f(t)$ and $\vartheta_c = f(t)$ and the relevant heat capacities.

With $\Delta\vartheta_h/\Delta t = 0.056\text{ K/s}$ (start of curve) and $c\Delta\vartheta_c/\Delta t = -0.023\text{ K/s}$ and with $C_{tot} = 1121\text{ J/K}$, we obtain:

$$P_h = 63\text{ W}; P_c = 26\text{ W}.$$

In the range considered, the voltage U_P (average value) was 12.4 V, so that we obtain the efficiency ratings $\eta_h = 1.3$ and $\eta_c = 0.52$. ($I = 4\text{ A}$, $T = 22\text{ }^\circ\text{C}$).

4. Fig. 8 shows the course of temperature in the water bath on the cold side when the hot side was cooled with the air cooler. The temperature ϑ_h of the hot side was approx. 72°C after 20 minutes (no blower). The maximum temperature difference $\vartheta_h - \vartheta_c = 60\text{ K}$ is thus attained and the pump output of the Peltier component is zero. When the blower was used, T_h remained constant at approx. 45°C after 20 minutes.